

HP-2 Recessed Flush Diffuser 1" T-Bar Starter/Independent Installation Instructions

Scan QR code for helpful video(s)

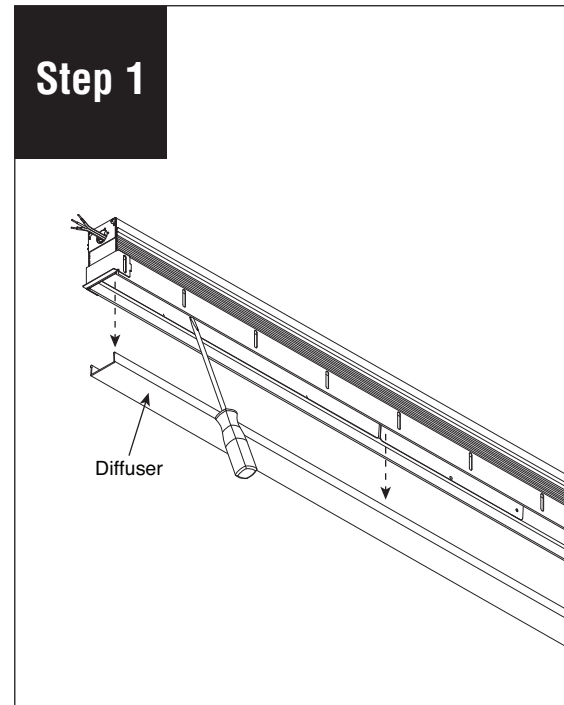

0 - 10V Dimming



Remove diffuser and set aside to prevent it from getting dirty or damaged.

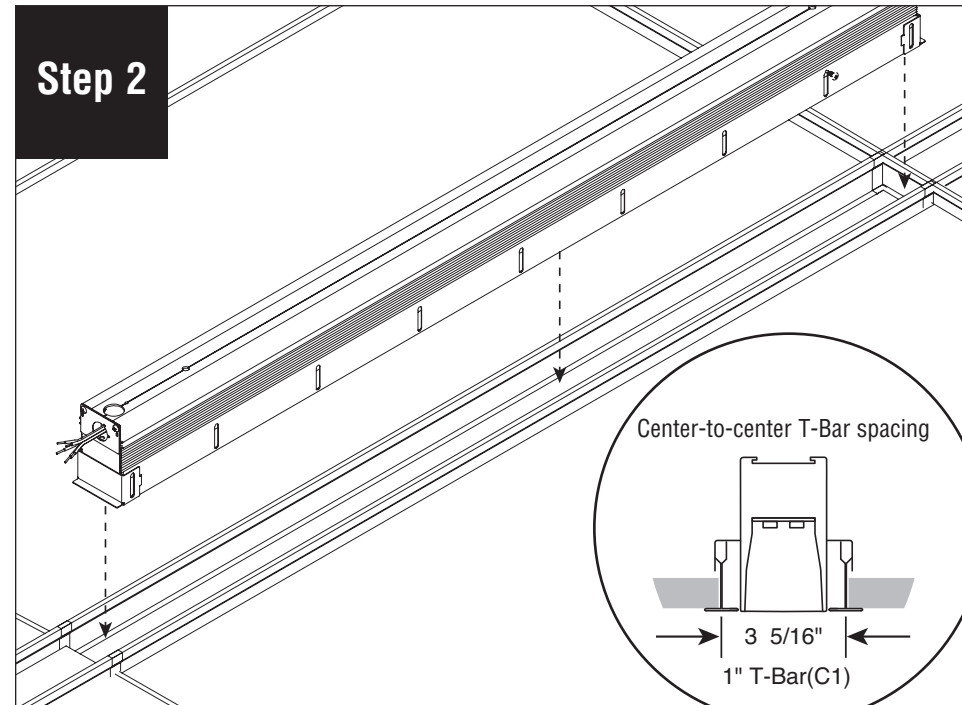

Place luminaire on T-Bar.

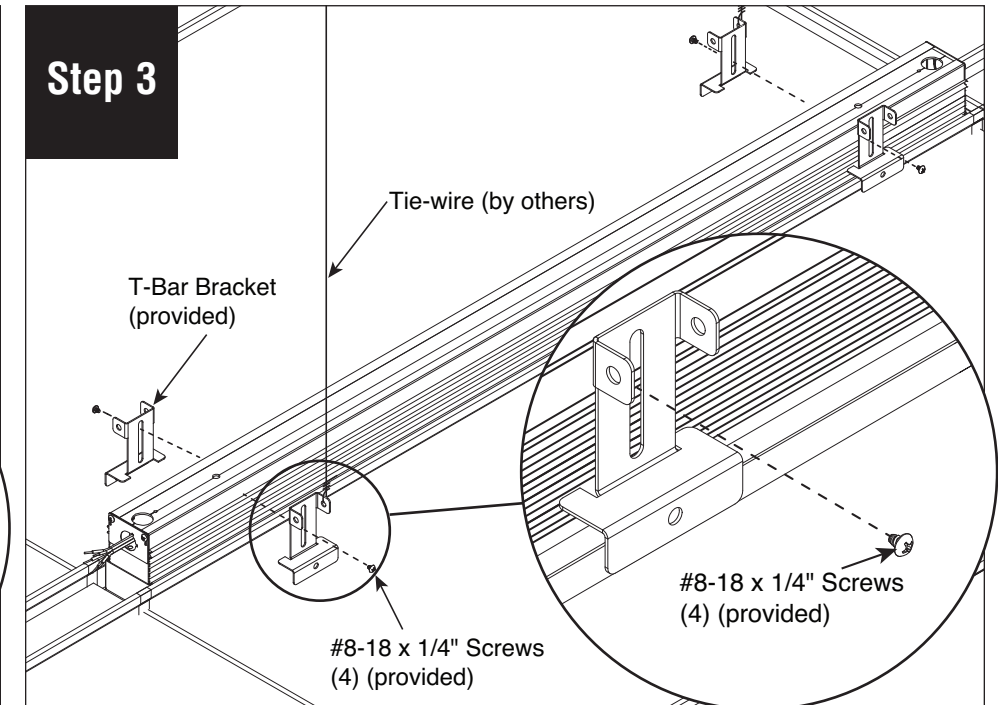

Install T-Bar bracket onto luminaire. Secure with #8-18 x 1/4" screws (provided). Secure luminaire to structure using tie-wire (by others), as per code.

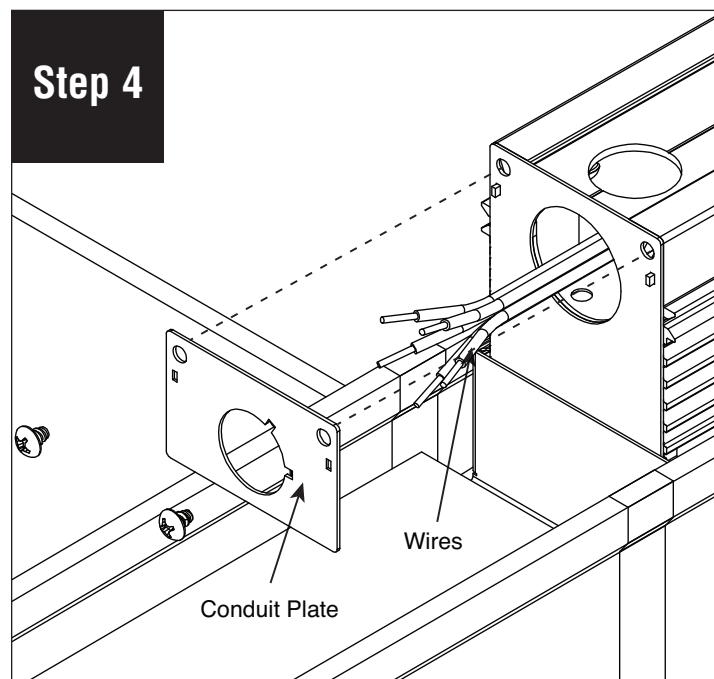

Remove conduit plate from luminaire.

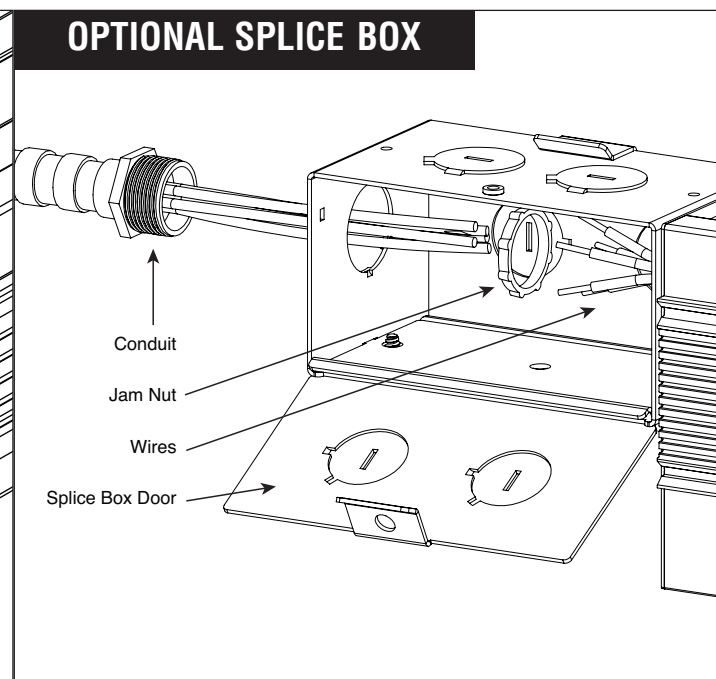

Open optional splice box door to access wiring.

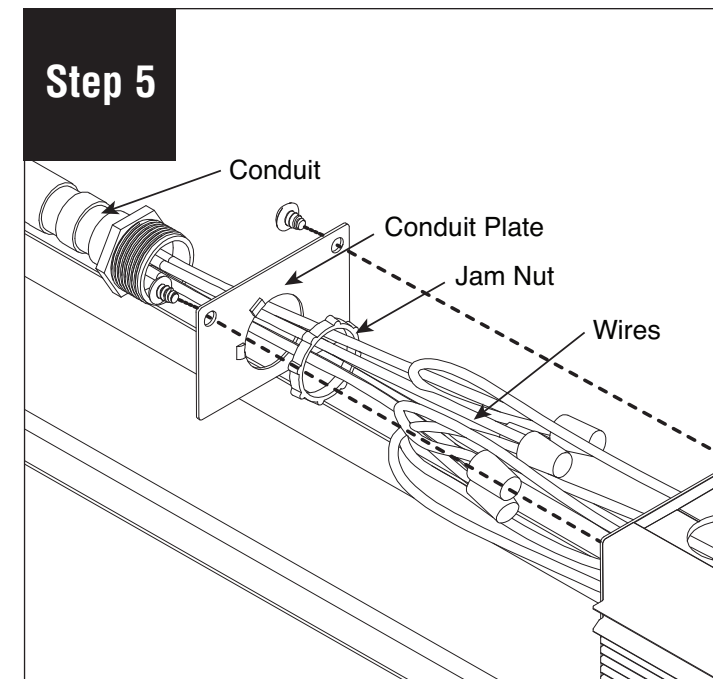

Run power cables through conduit plate and jam nut. Make electrical connections. Secure conduit onto conduit plate with jam nut, and reinstall conduit plate carefully not to damage any wiring.

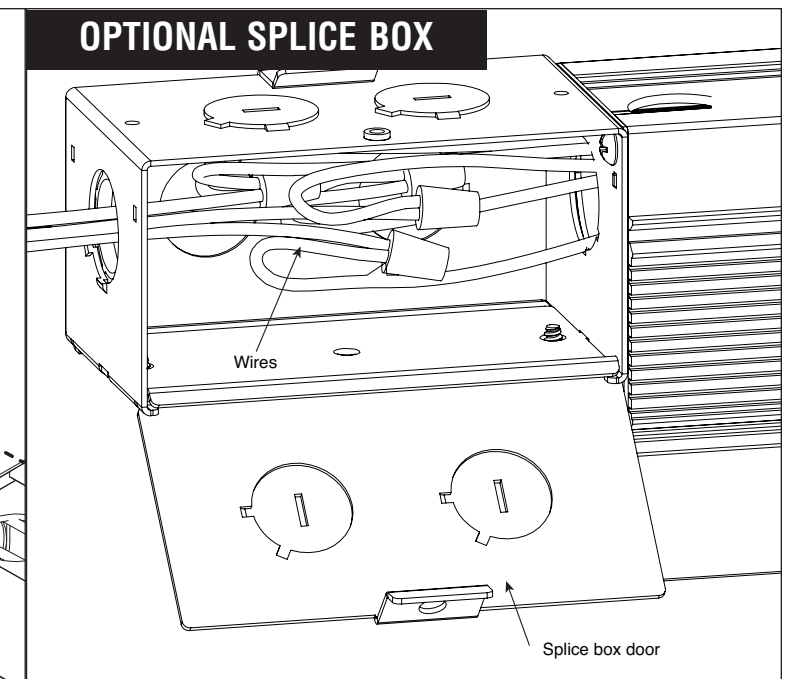

Run power cable through knock-out. Make electrical connections. Secure conduit on to splice box with jam nut and close splice box door.

Note: All power connections to be installed to local/national codes by a Certified Electrician.

HP-2 Recessed Flush Diffuser 1" T-Bar Starter/Independent Installation Instructions

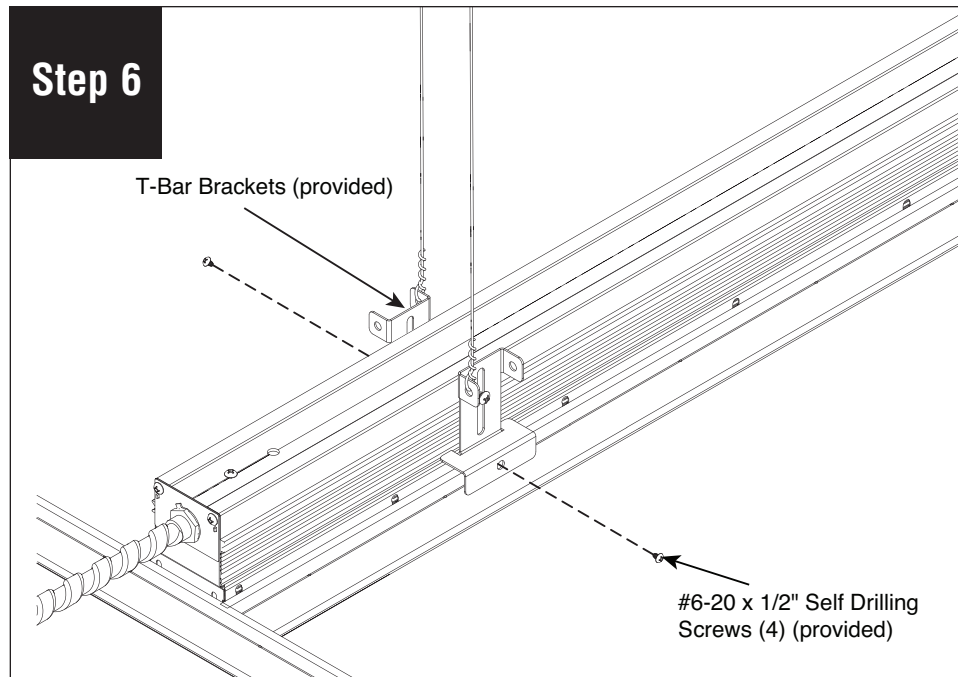

Secure luminaire to T-Bar by driving #6-20 x 1/2" self drilling screws (provided) through the T-Bar brackets (provided) into the T-Bar.

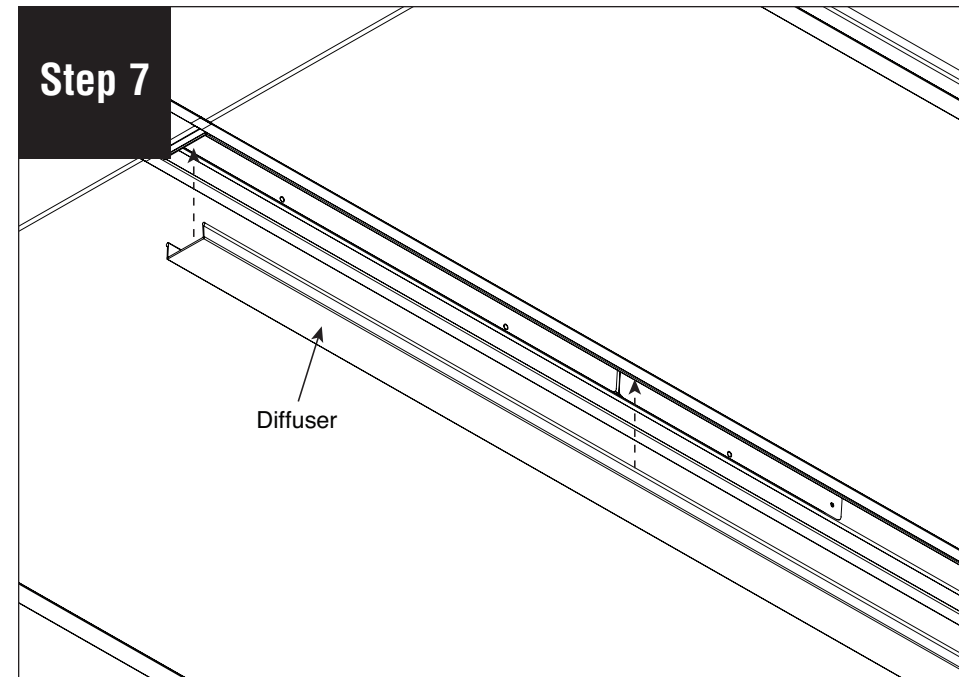

Reinstall diffuser and turn power on to luminaire.

Note: All power connections to be installed to local/national codes by a Certified Electrician.

HP-2 Recessed Flush Diffuser 1" T-Bar Joiner/Ender Installation Instructions

Scan QR code for helpful video(s)



0 - 10V Dimming

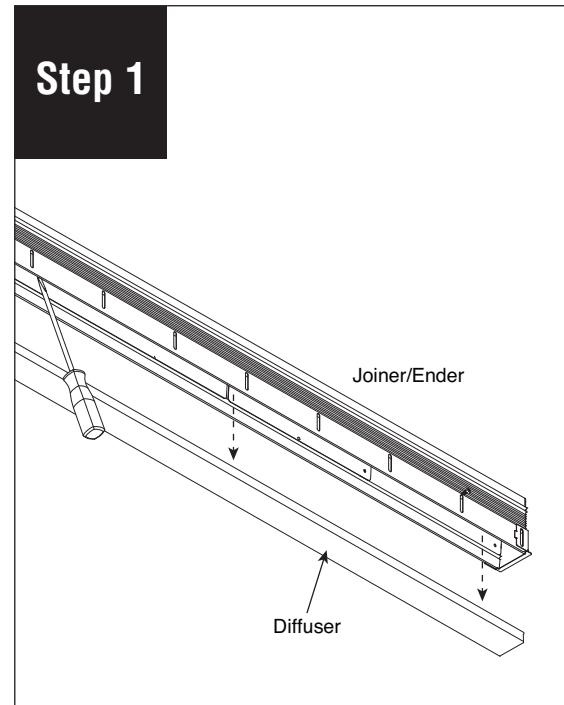

Remove diffuser and set aside to prevent it from getting dirty or damaged.

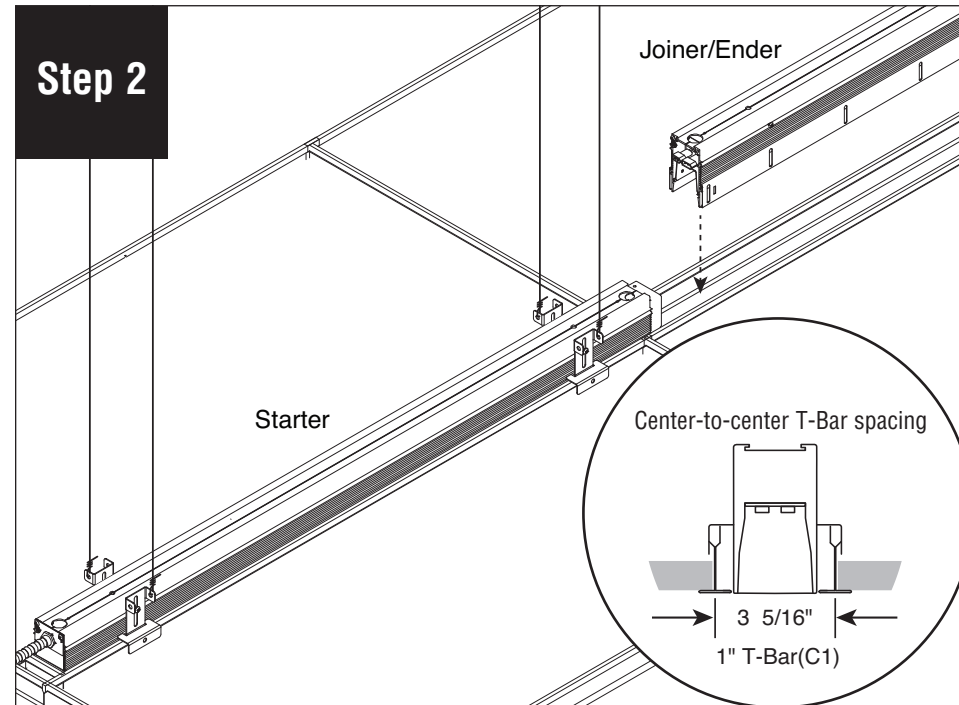

Install joiner/ender onto ceiling next to starter. Align the starter and joiner/ender luminaires and slide them together.

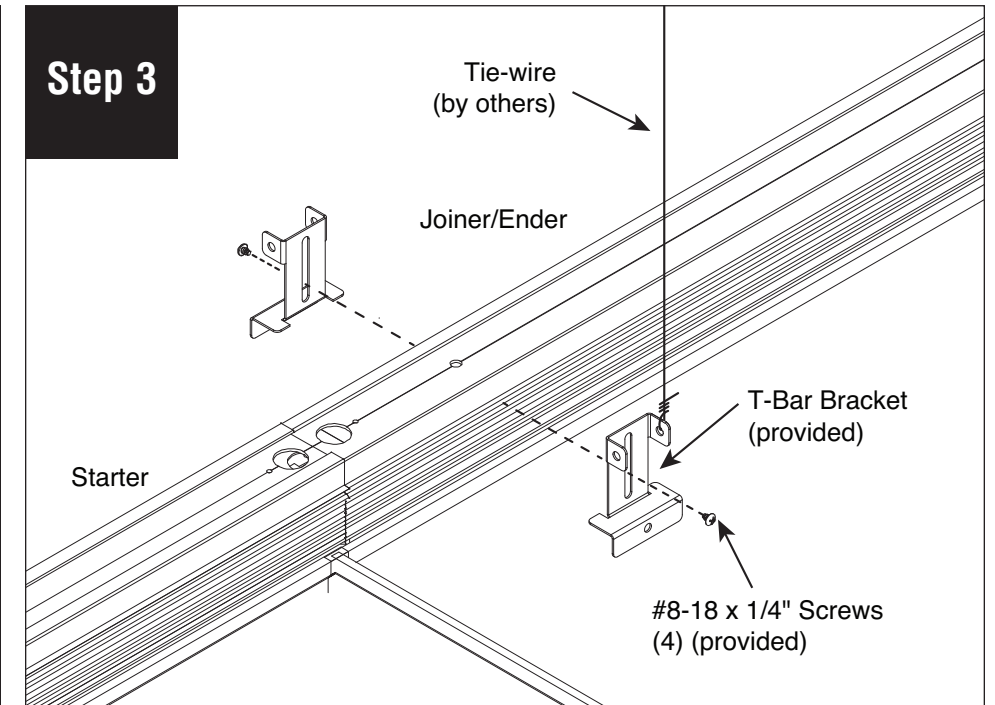

Install T-Bar bracket onto joiner/ender. Secure with #8-18 x 1/4" screws (provided). Secure all luminaires to structure using tie-wire (by others), as per code.

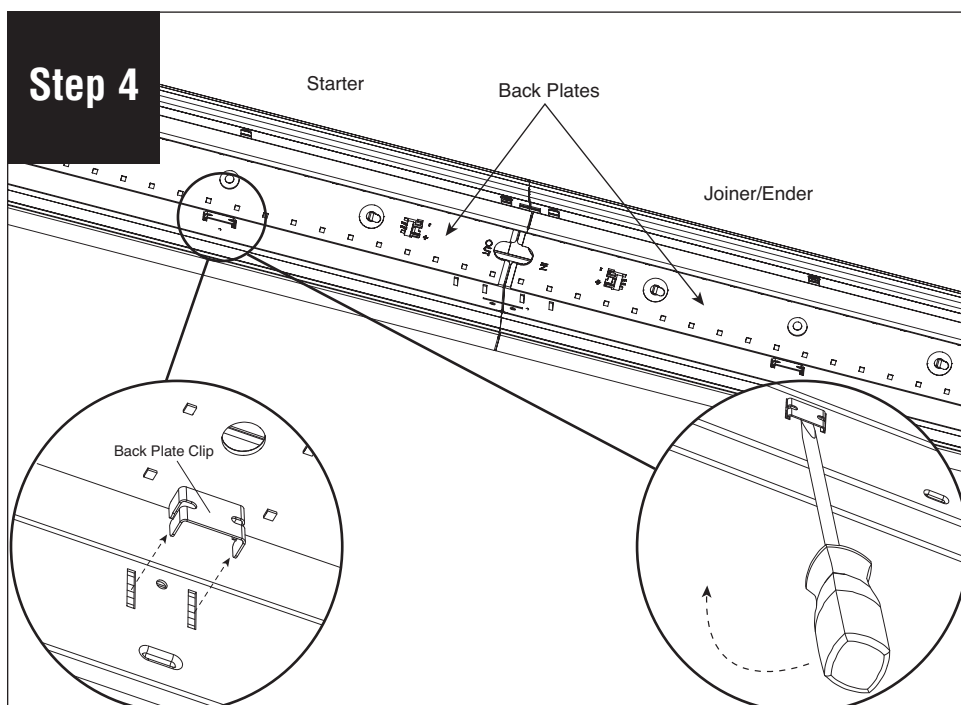

At the joint of luminaires. Remove back plate clips (provided) to release back plates. We recommend using a flat head screwdriver to get them loose. **CAUTION: Do not lose these pieces.**

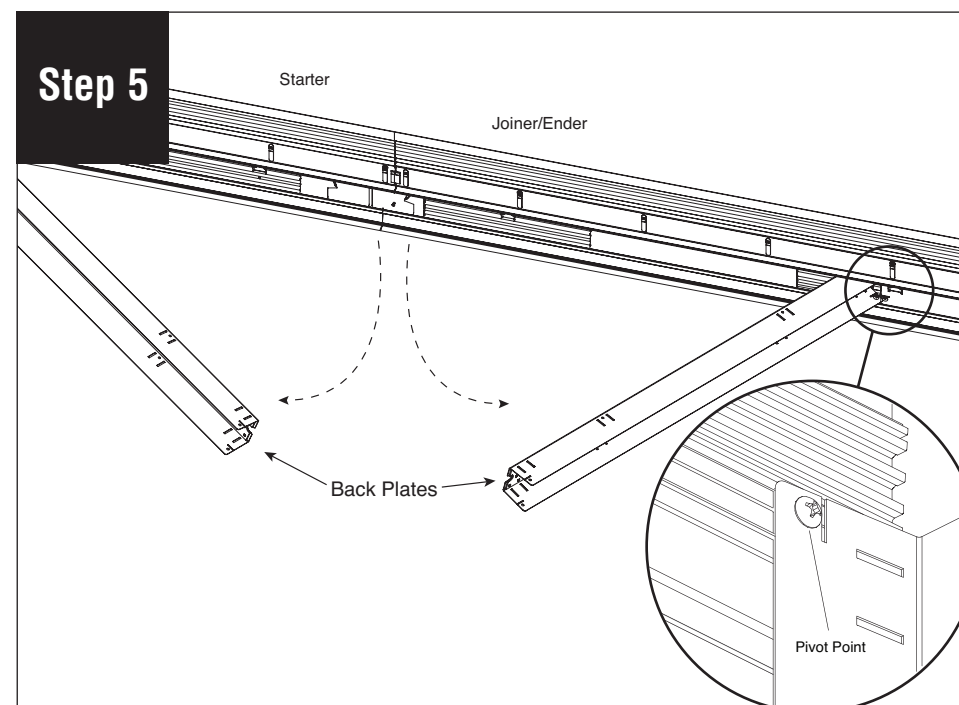

Slowly swing down back plates. **CAUTION: Do not twist back plate when swinging down - it will come out of the support extrusion.** Note that the screw shown is the pivot point and the back plate can be slid a few inches either way for ease of access to the driver space.

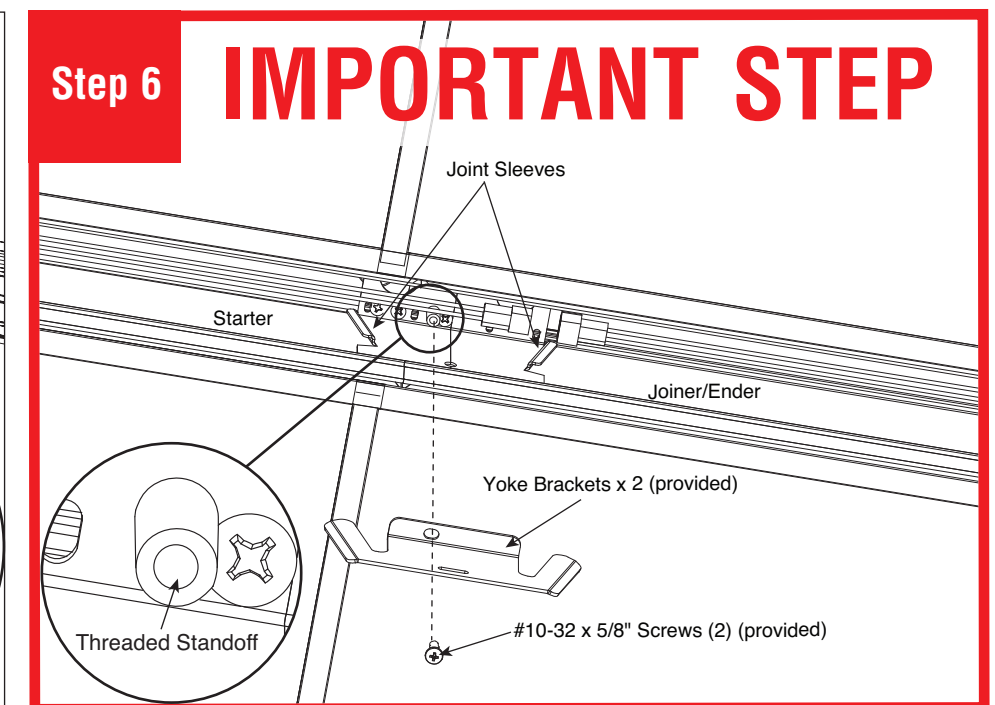

IMPORTANT STEP: Secure joint with two yoke brackets (provided) using #10-32 x 5/8" screws (provided). **CAUTION:** When installed correctly these brackets will pull luminaires together to make a tight joint. Do not over-tighten.

Note: All power connections to be installed to local/national codes by a Certified Electrician.

HP-2 Recessed Flush Diffuser 1" T-Bar Joiner/Ender Installation Instructions

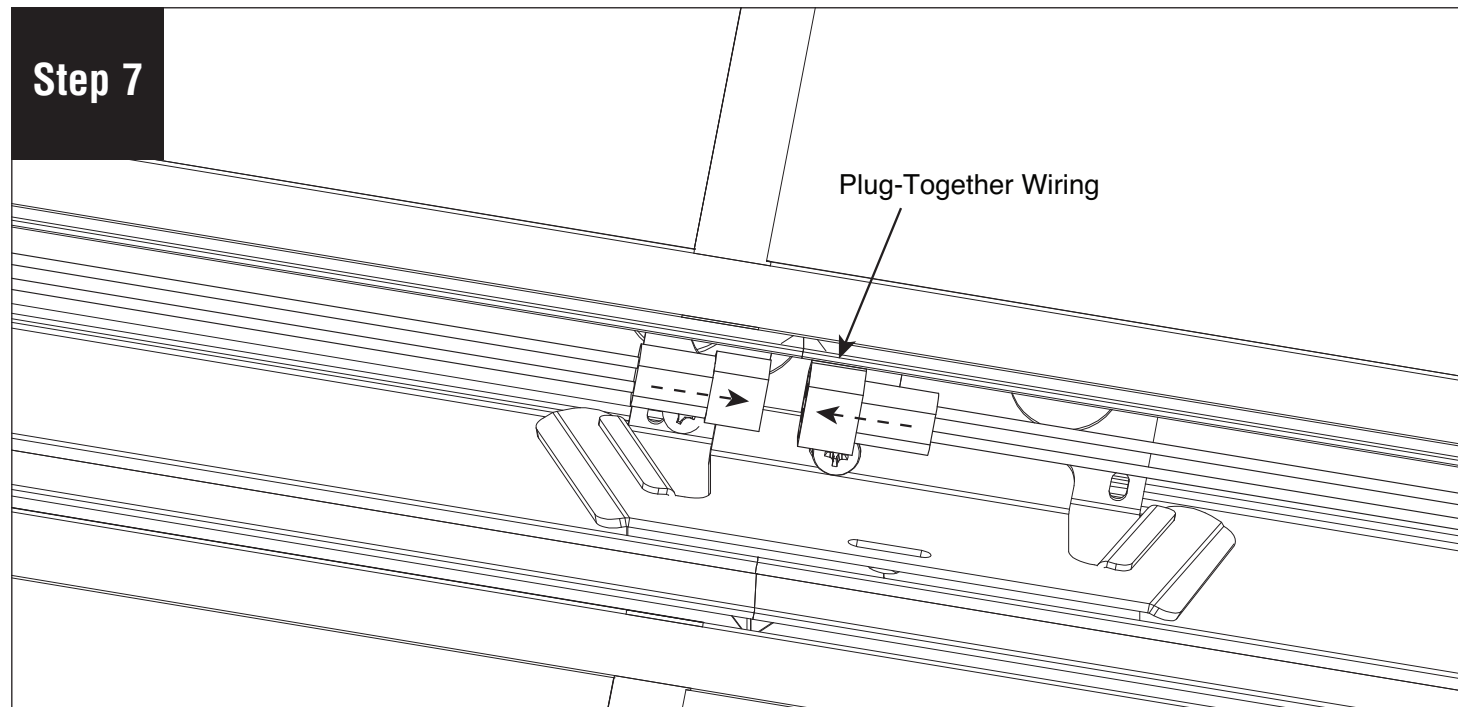

Connect plug-together connection.

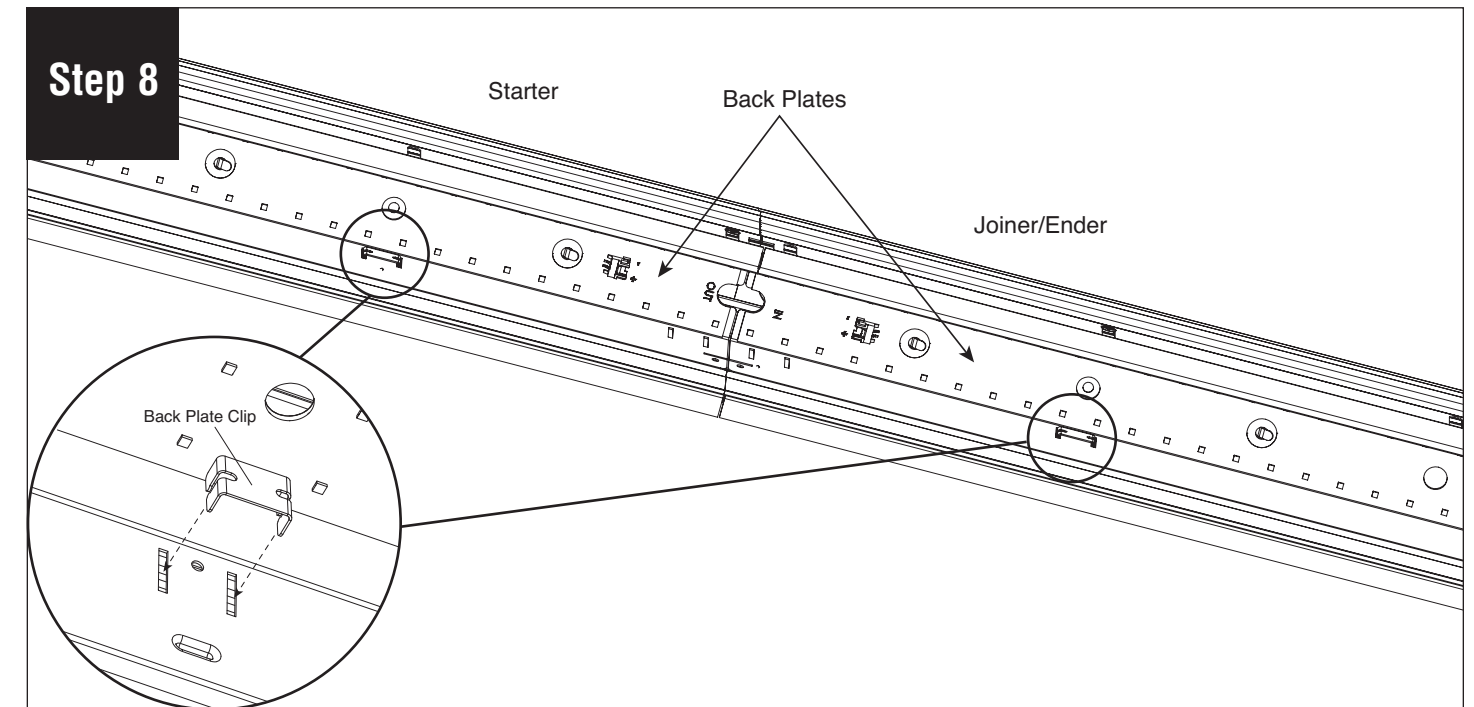

Replace all back plates by holding them in their original position and pushing the clips back in. Make sure wire connections are not pinched. (If 1 ft. back plate assembly is near joint, reconnect feed harness to LED board.)

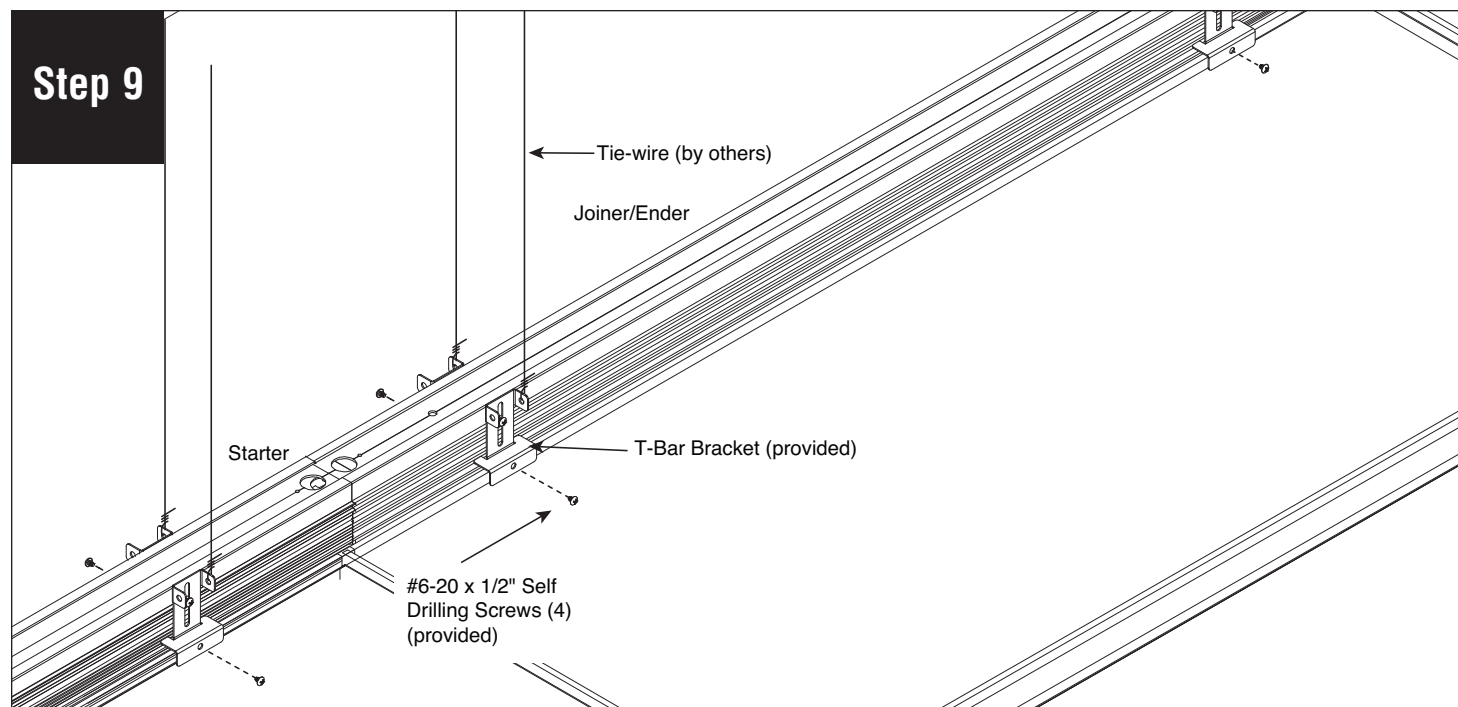

Secure all luminaires to the T-Bar by driving #6-20 x 1/2" self drilling screws (provided) through the T-Bar brackets (provided) into the T-Bar.

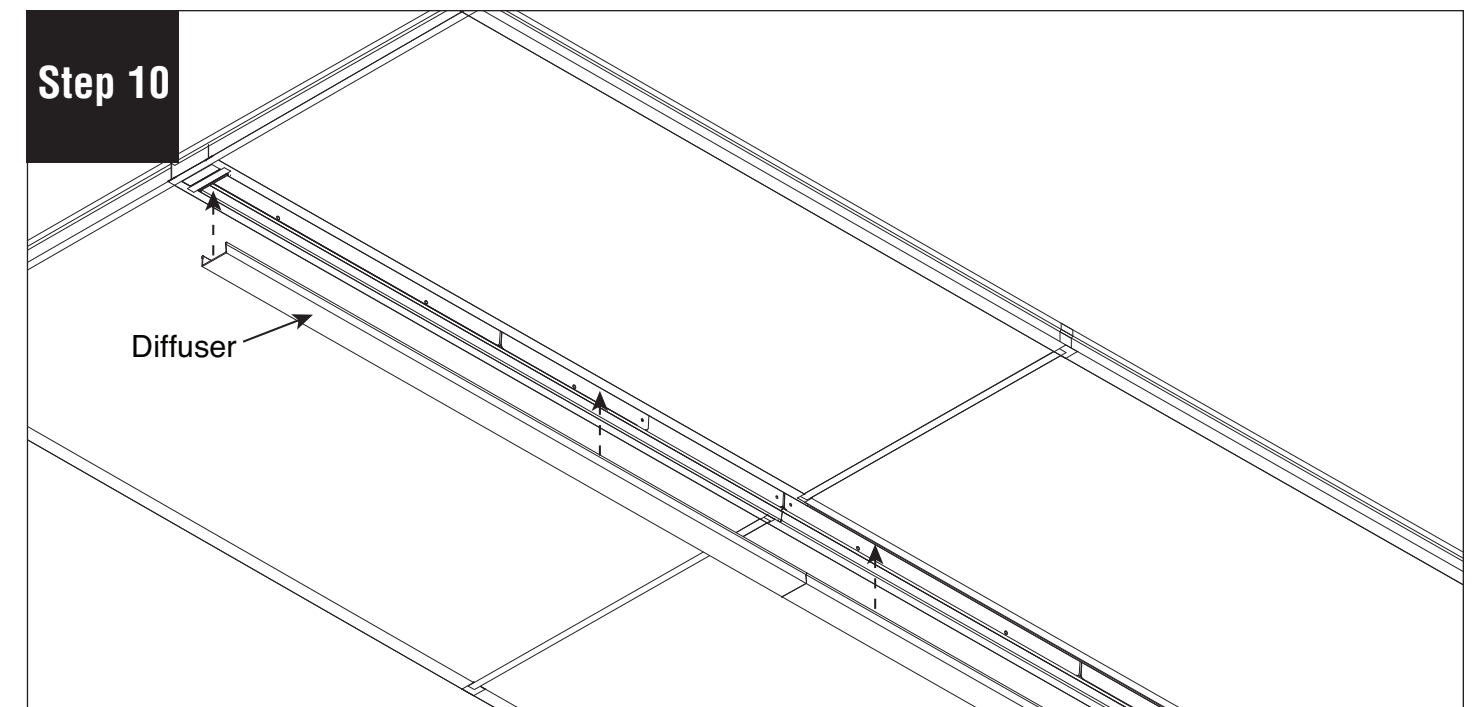

Reinstall diffusers and turn power on to luminaires.

Note: All power connections to be installed to local/national codes by a Certified Electrician.