

# HP-2 Recessed Flush Diffuser Spackle Flange Inside Corner Installation Instructions

Scan QR code for helpful video(s)



0 - 10V Dimming

## Step 1

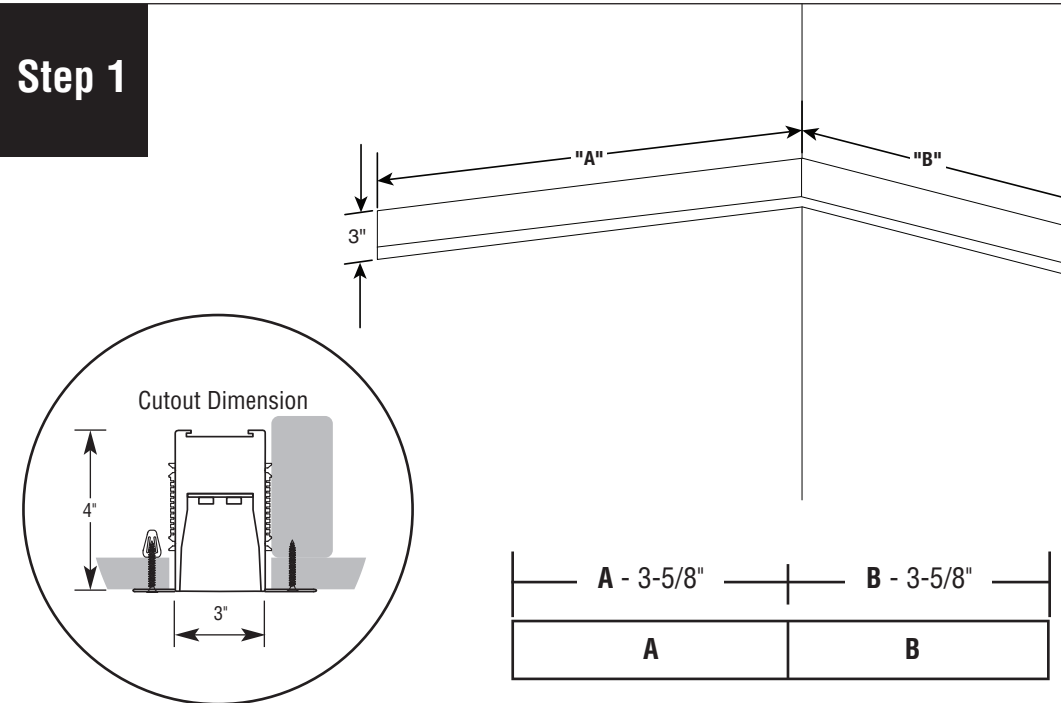

Subtract 3-5/8" from body/row length (A) and body/row length (B) to simplify installation. Luminaire needs to be installed next to support blocking. **NOTE:** Tolerances on dimensions are +/- 1/16". Please contact factory for dimensions of tailored luminaires with non-90° angles.

## Step 2

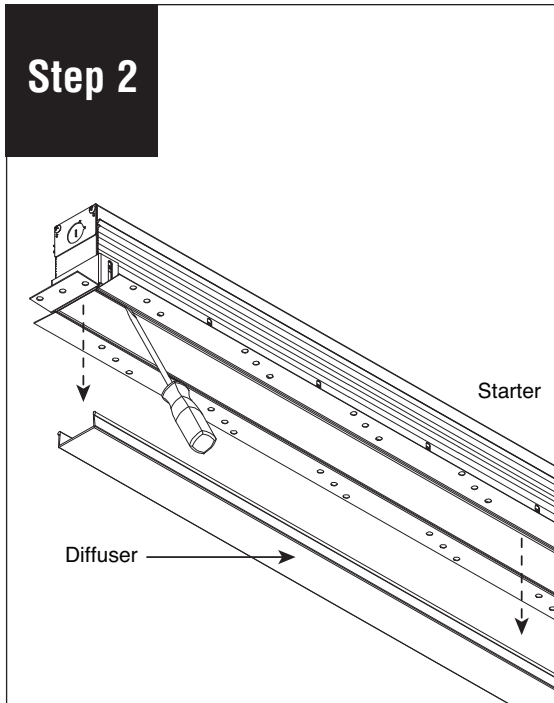

Remove diffuser and set aside to prevent it from getting dirty or damaged.

## Step 3

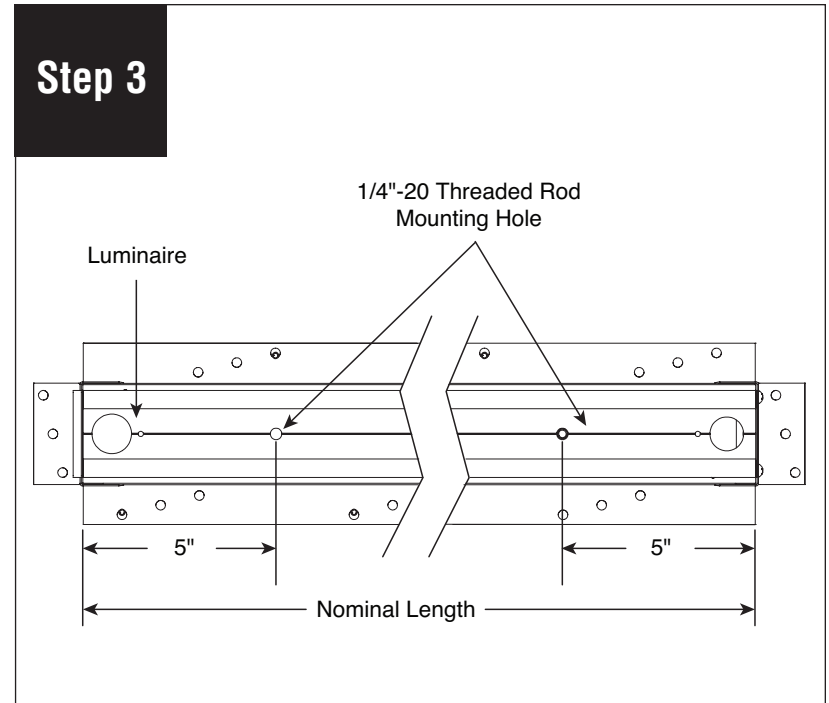

Refer to threads and feed hole locations above before connecting luminaire wires.

## Step 4

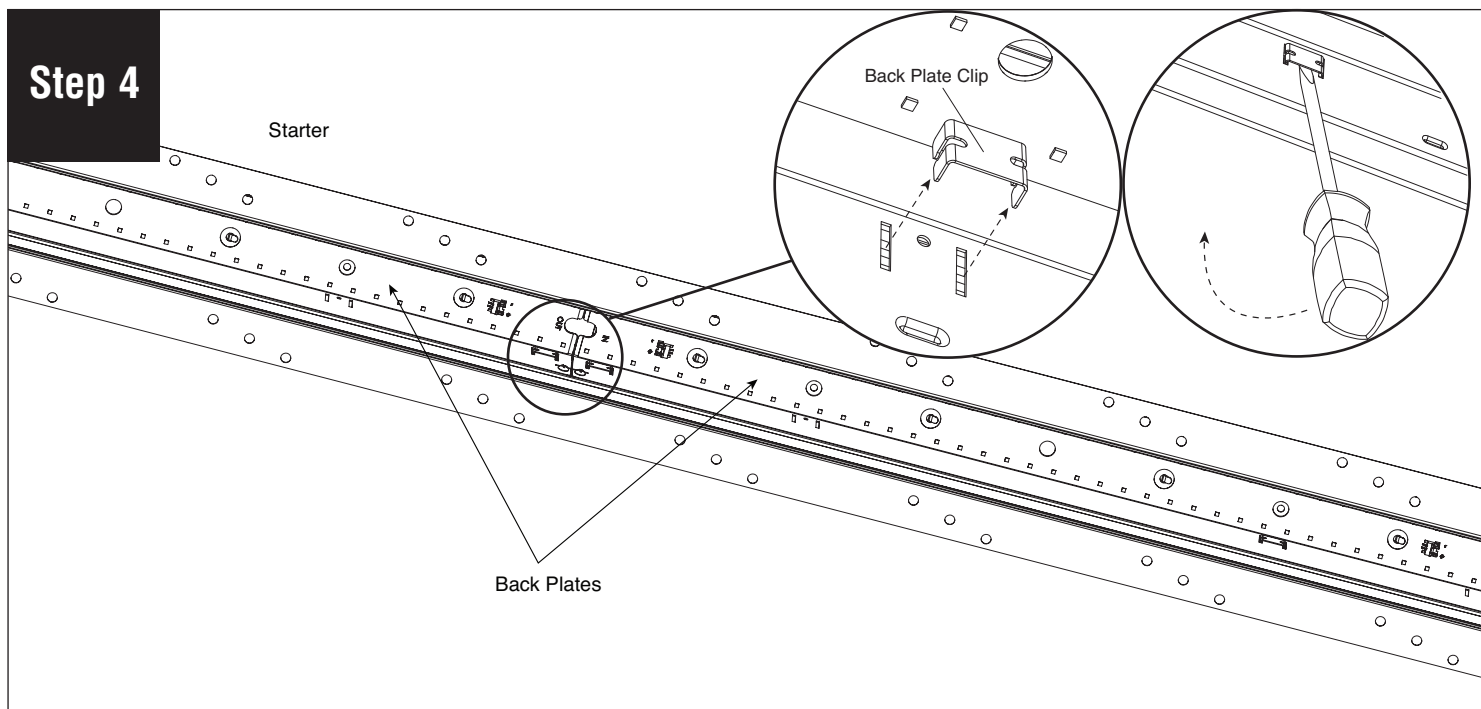

Remove back plate clips (provided) to release back plate. We recommend using a flat head screwdriver to get them loose. **CAUTION: Do not lose these pieces.**

## Step 5

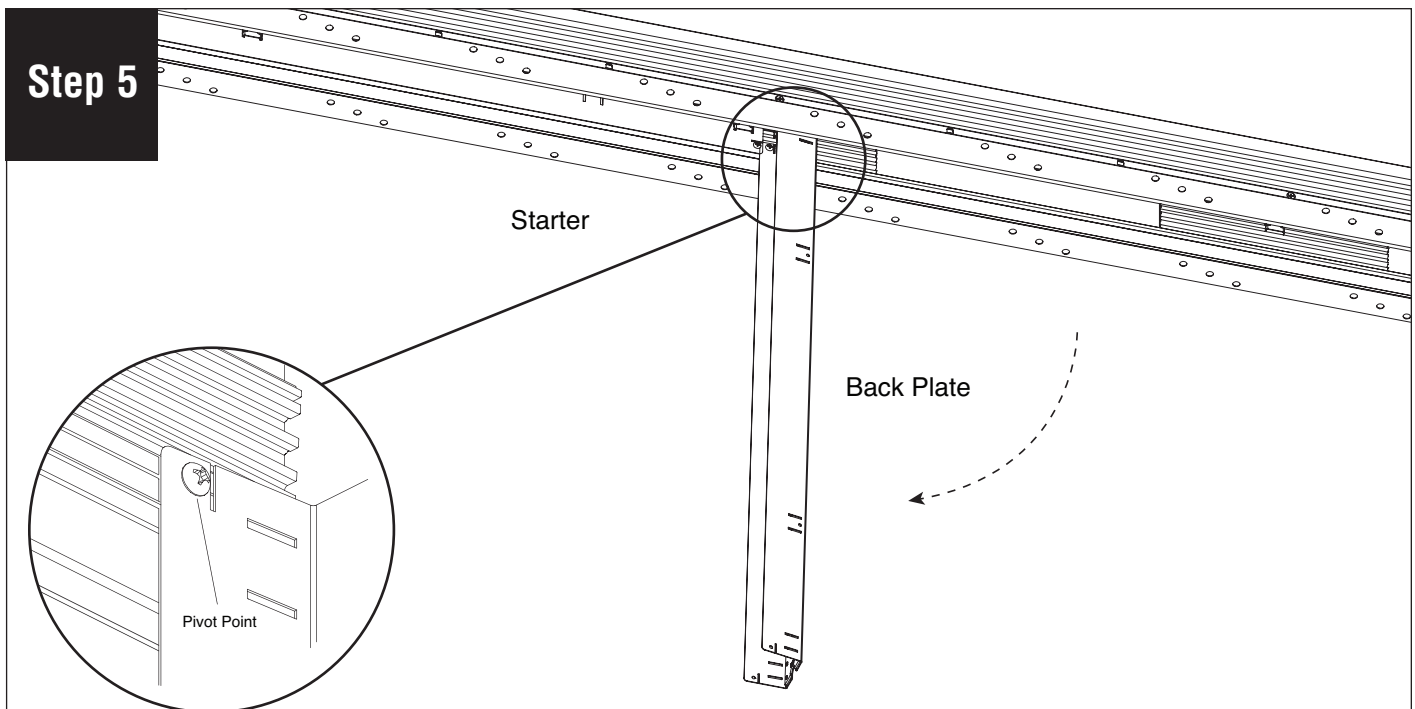

Align luminaire within rough opening in drywall and 1/4"-20 threaded rod (by others). Slowly swing out back plate(s). **CAUTION: Do not twist back plate when opening - it will come out of the support extrusion.** Note that the screw shown is the pivot point and the back plate can be slid a few inches either way for ease of access to the driver space.

**Note:** All power connections to be installed to local/national codes by a Certified Electrician.

# HP-2 Recessed Flush Diffuser Spackle Flange Inside Corner Installation Instructions

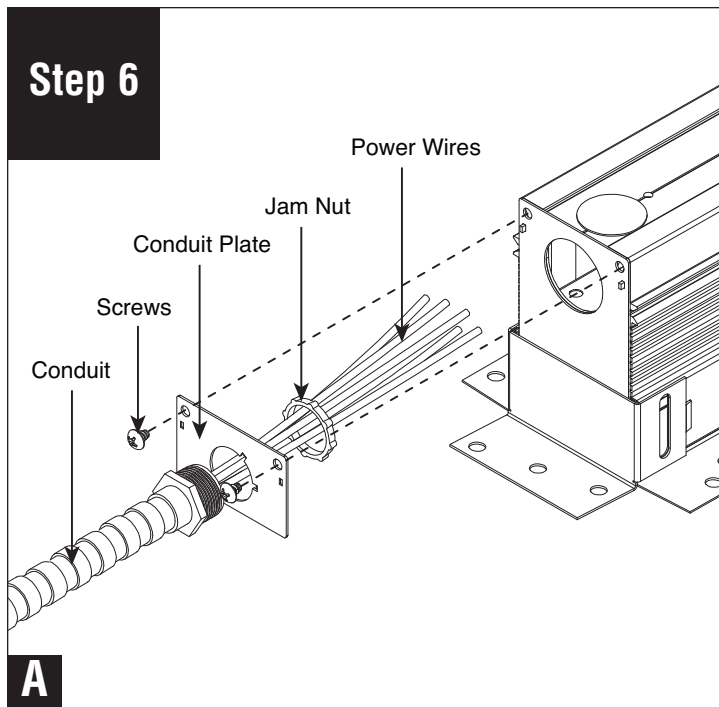

**A.** Standard installation. Remove conduit plate from luminaire. Remove jam nut from conduit then insert wires and connector through feed hole. Secure conduit with jam nut.

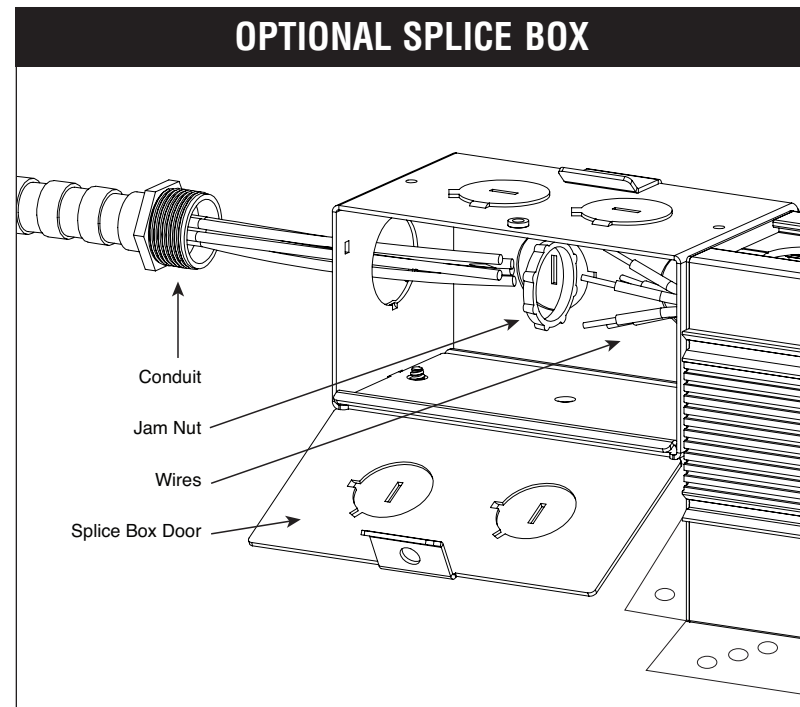

Open optional splice box door to access wiring.

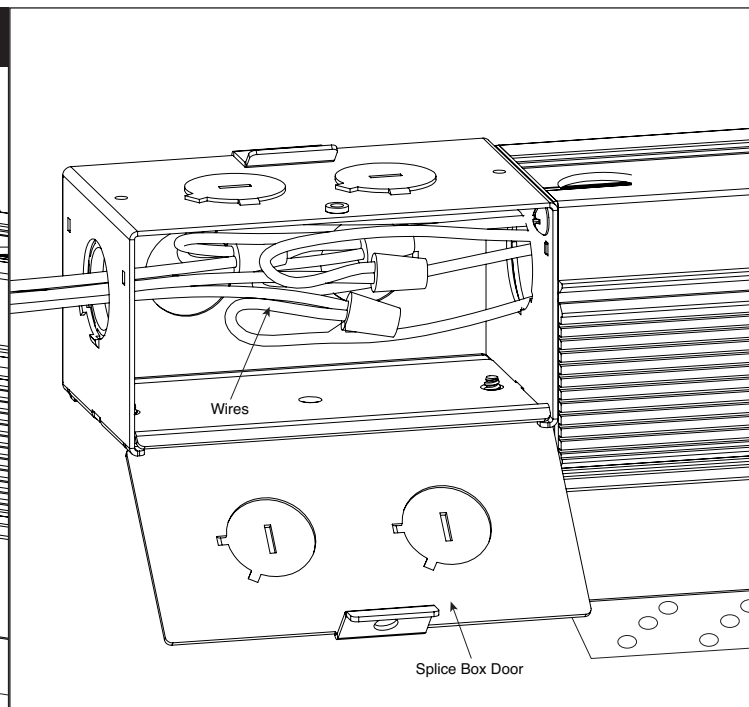

Run power cable through knock-out. Make electrical connection. Secure conduit on to splice box with jam nut and close splice box door.

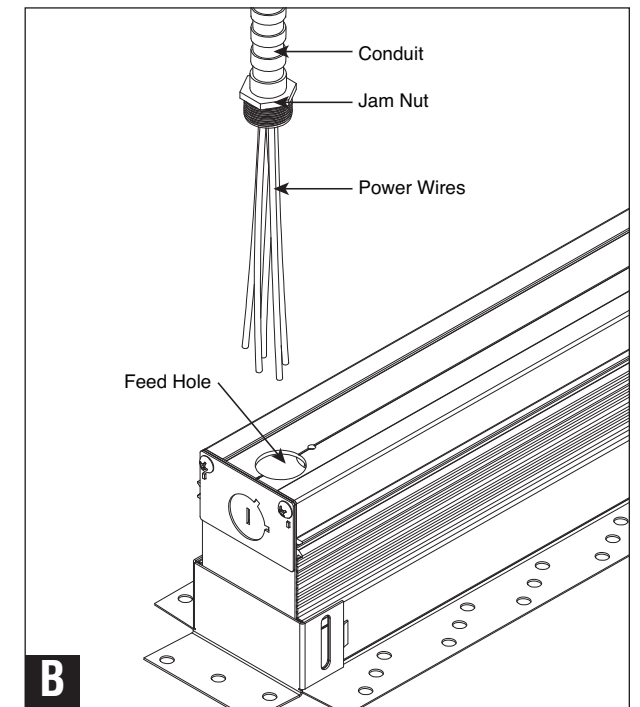

**B.** Alternate option from top.

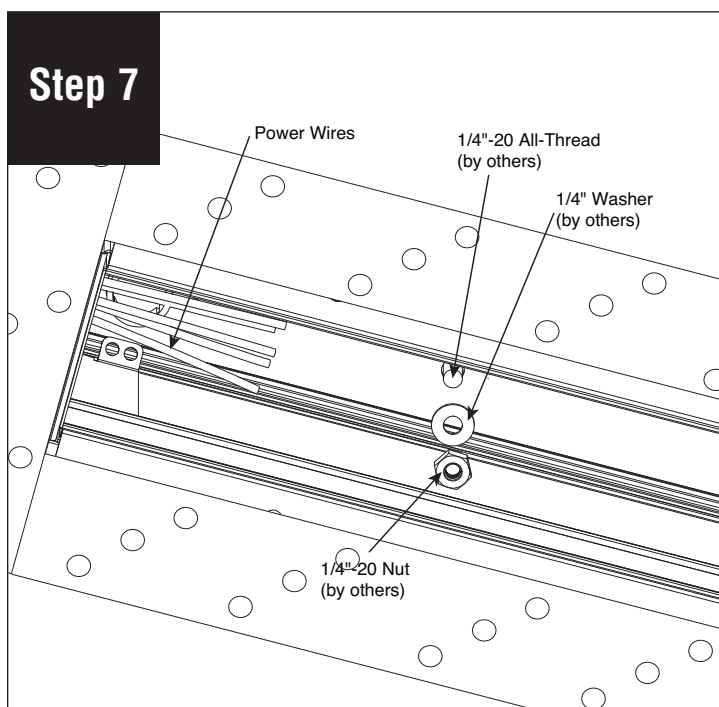

Secure to structure by installing 1/4" washers (by others) and 1/4"-20 nuts (by others) onto 1/4"-20 threaded rod (by others).

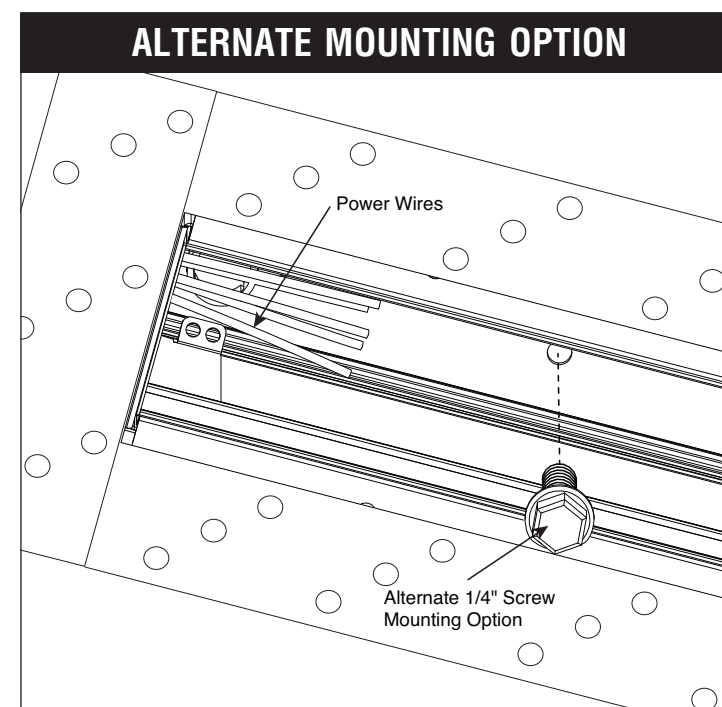
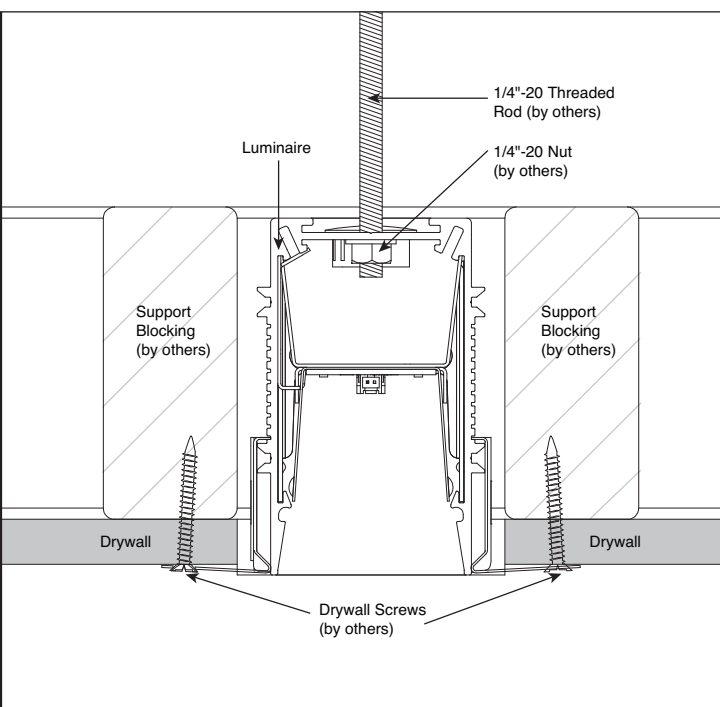

**Alternate Option** - Install 1/4" screw (by others) through mounting hole into proper structurally supported blocking (by others).

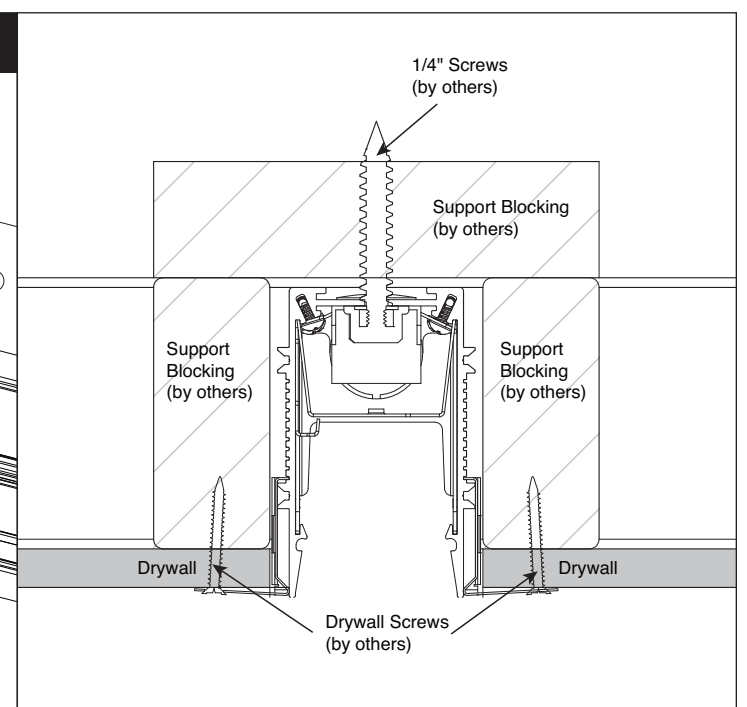

**Note:** All power connections to be installed to local/national codes by a Certified Electrician.

# HP-2 Recessed Flush Diffuser Spackle Flange Inside Corner Installation Instructions

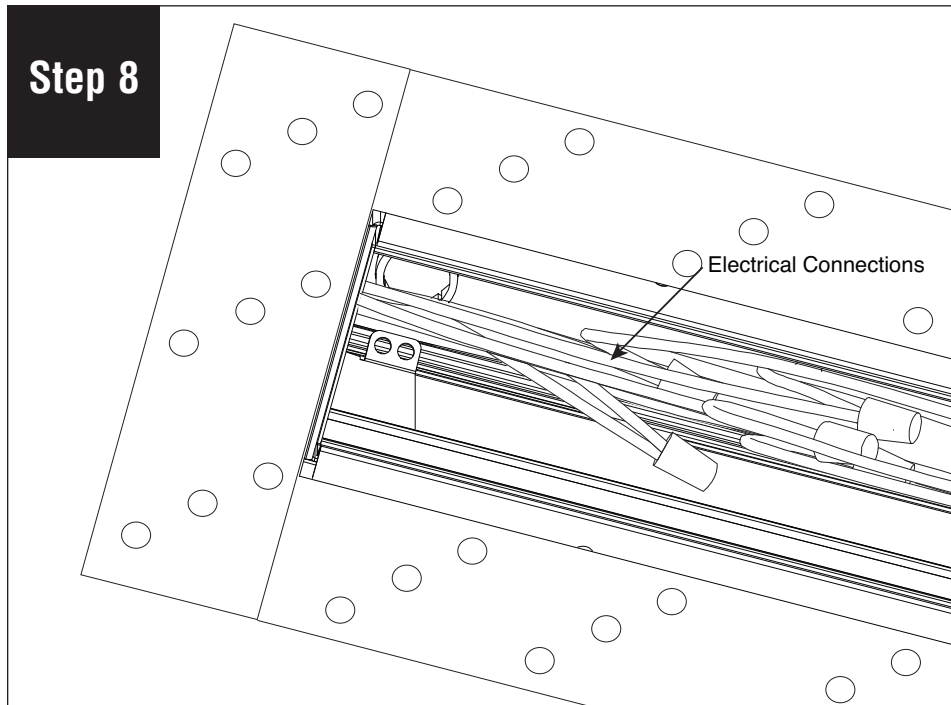

Make electrical connections.

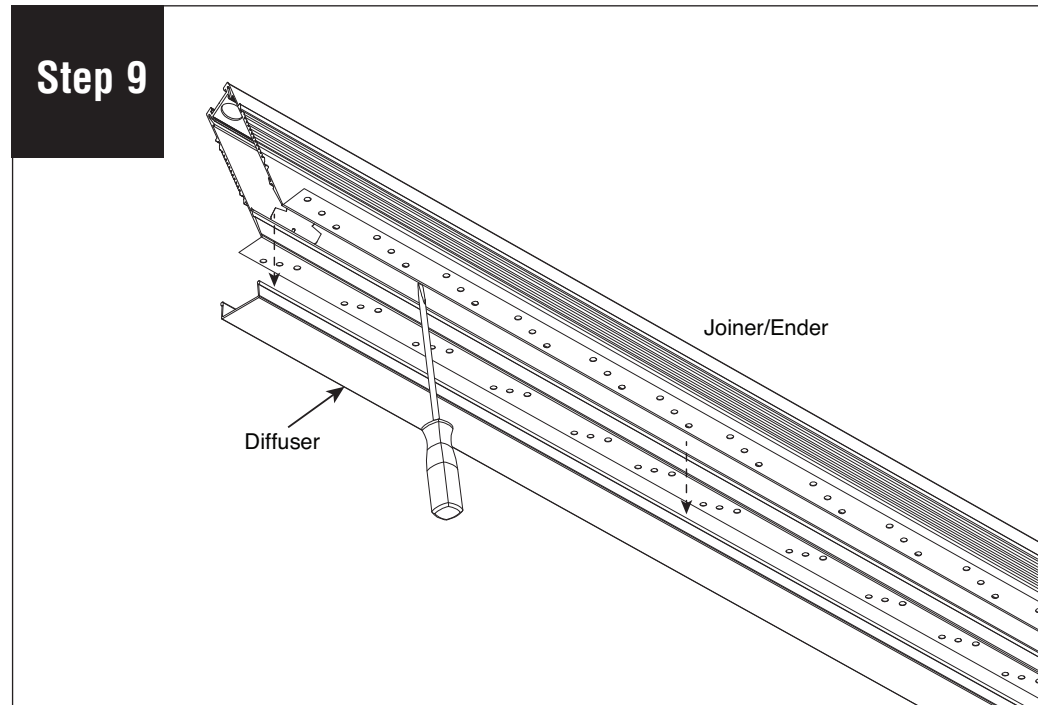

Remove diffuser from joiner/ender and set aside to prevent it from getting dirty or damaged.

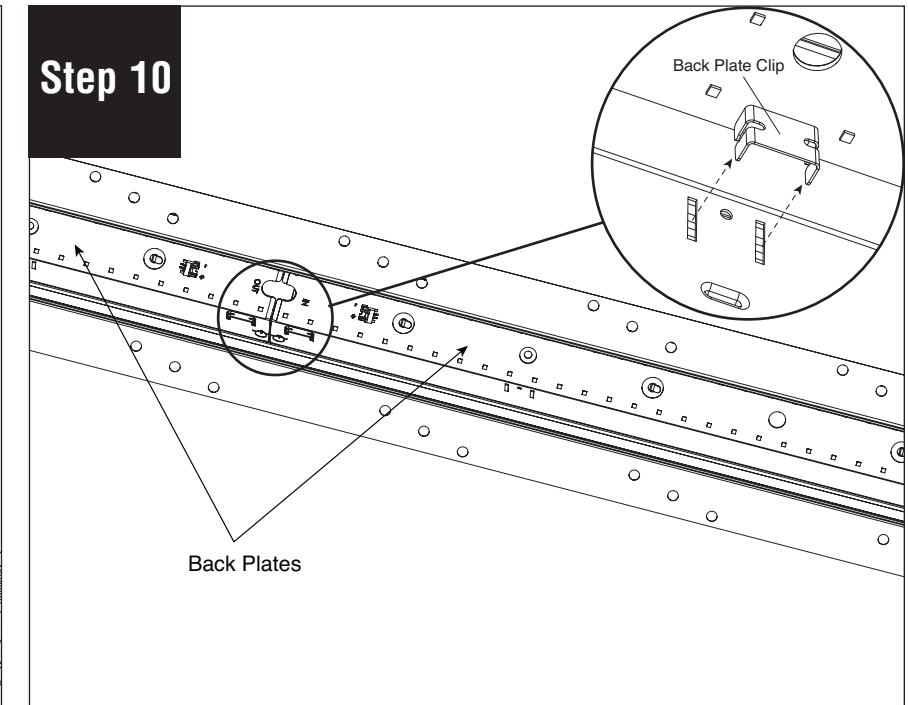

Remove back plate clips (provided) on the joiner/ender to release the back plates and slowly swing out back plates.

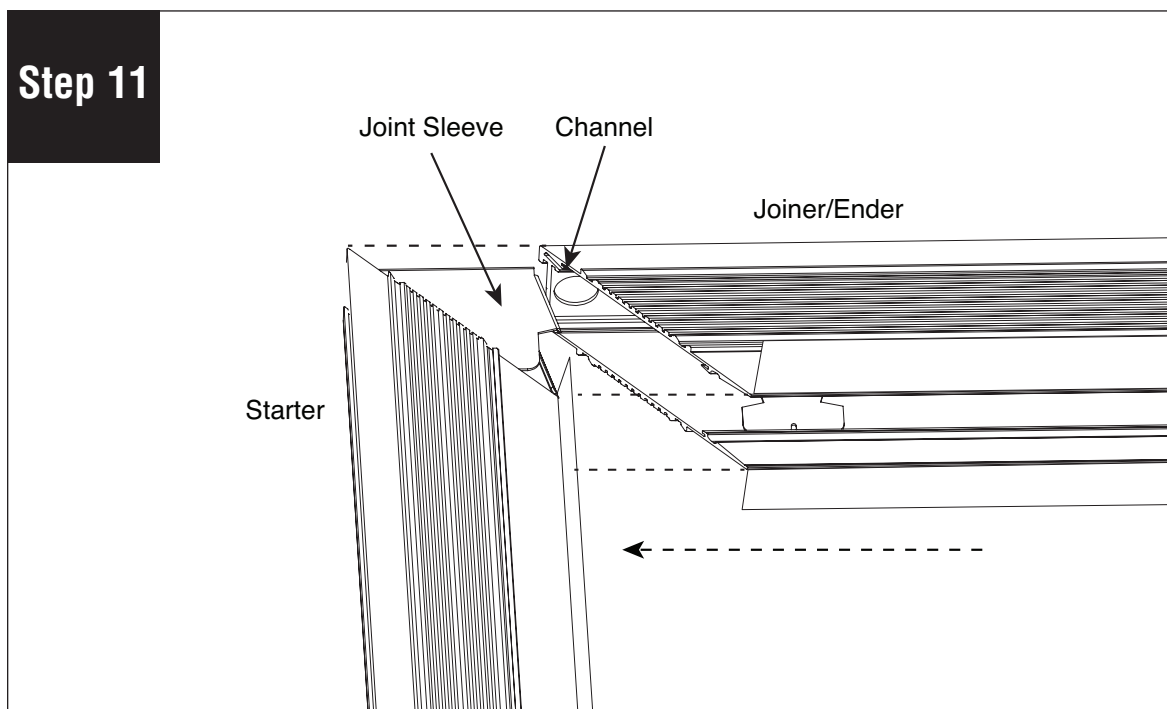

Insert joiner/ender luminaire into rough wall opening, corner end first. Slide joiner/ender luminaire onto starter luminaire, then install into rough cut out. Align and insert joint sleeve with channel in body.

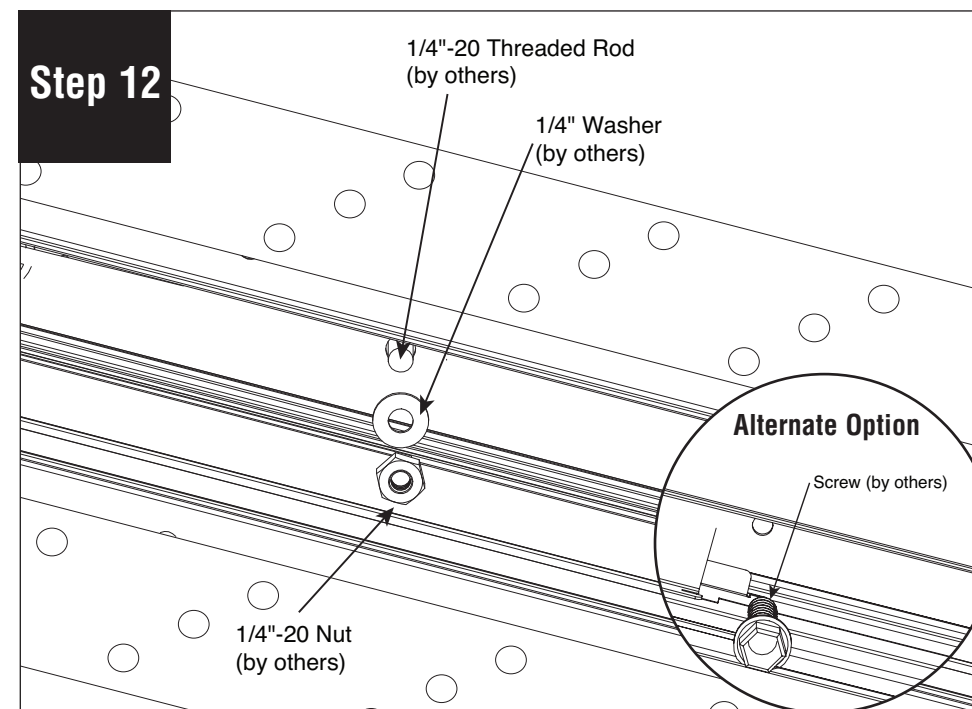

Secure to structure by installing 1/4" washers (by others) and 1/4"-20 nuts (by others) onto 1/4"-20 threaded rod (by others). **Alternate Option** - Install 1/4" screw (by others) through mounting hole into proper structurally supported blocking (by others).

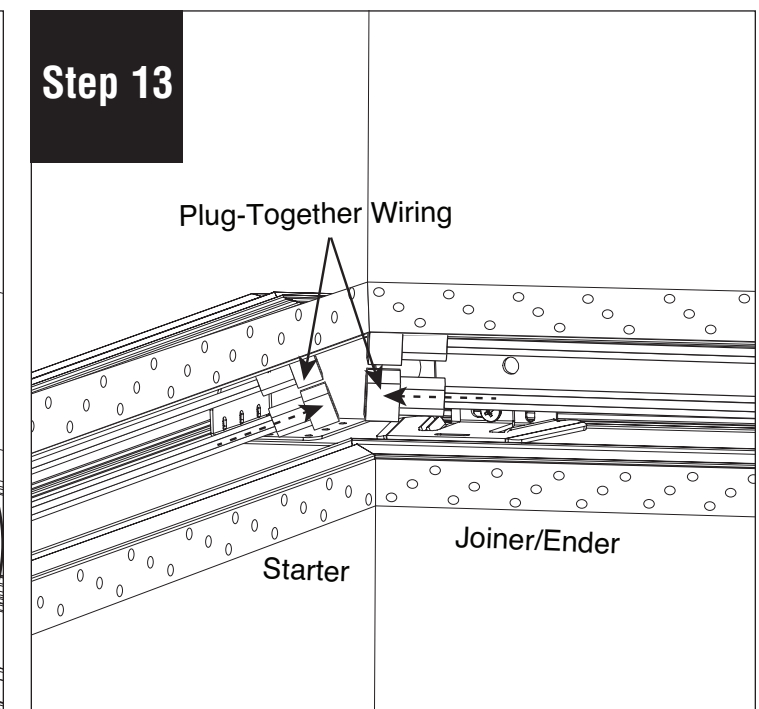

Connect plug-together wiring.

**Note:** All power connections to be installed to local/national codes by a Certified Electrician.

# HP-2 Recessed Flush Diffuser Spackle Flange Inside Corner Installation Instructions

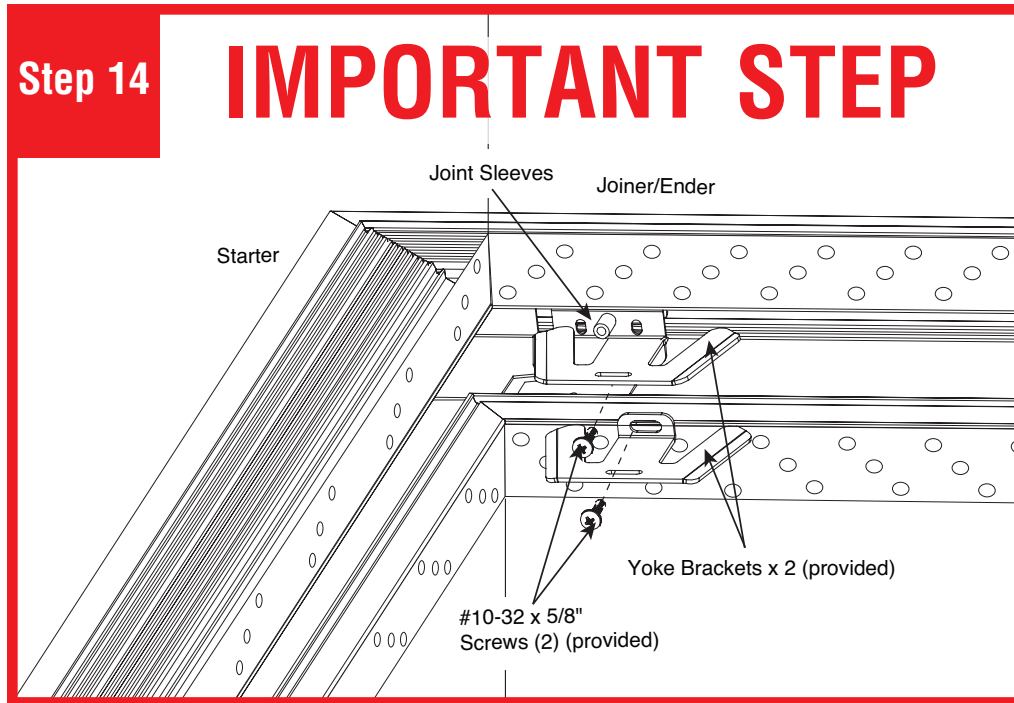

**IMPORTANT STEP:** Secure joint with two yoke brackets (provided) using #10-32 x 5/8" screws (provided). **CAUTION:** When installed correctly these brackets will pull luminaires together to make a tight joint. Do not over-tighten.

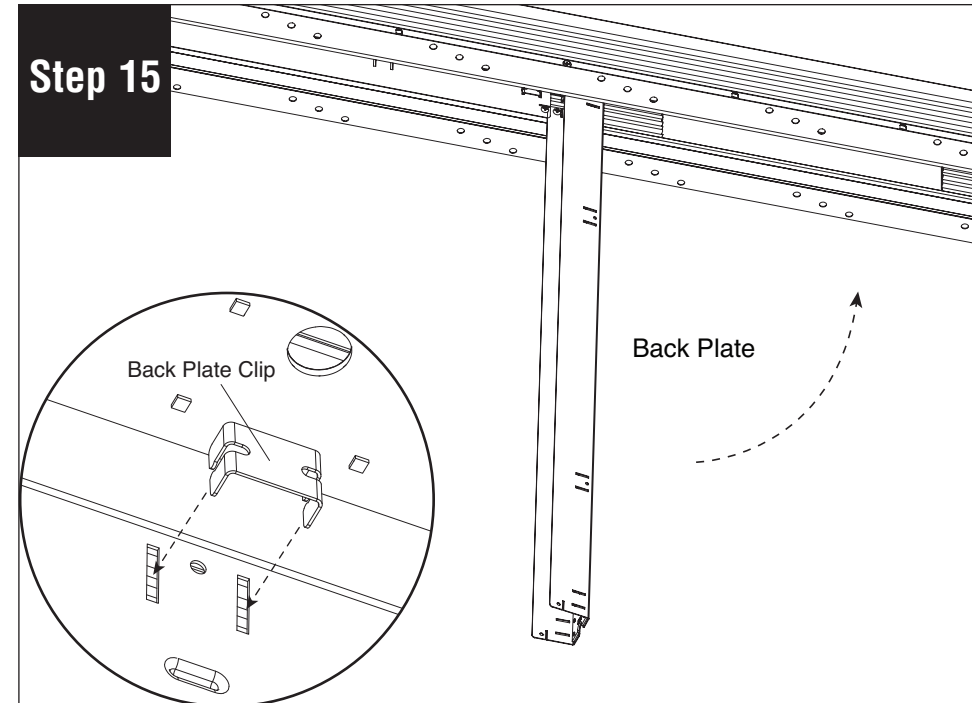

Replace all back plates by holding them in their original position and pushing the clips back in. Make sure wire connections are not pinched. (If 1 ft. back plate assembly is near joint, reconnect feed harness to LED board.)

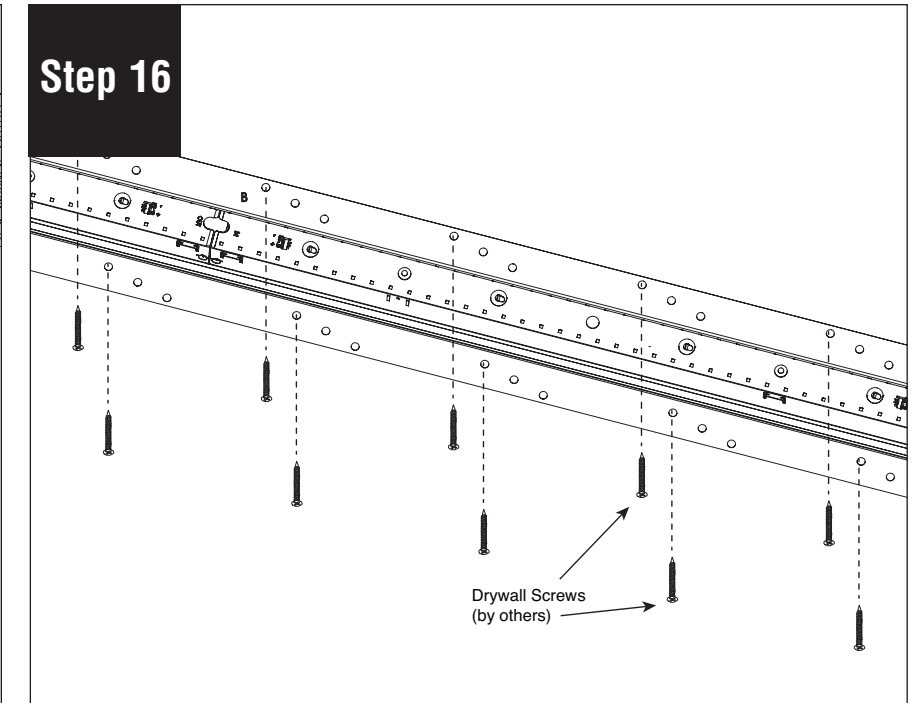

Fasten luminaires to wall with drywall screws (by others) through the flange into the blocking.

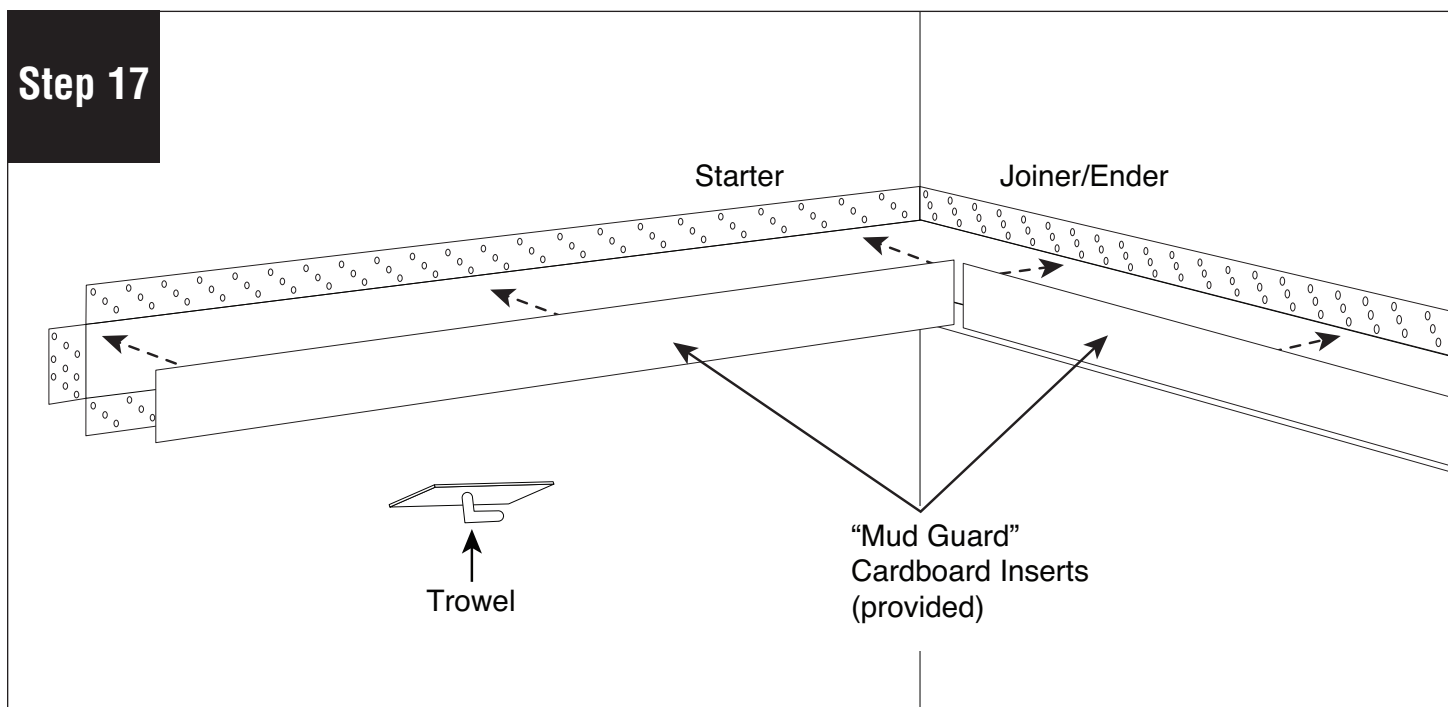

Install "mud guard" cardboard inserts (provided) to help prevent spackle from getting into the luminaires. Use spackle to cover up the flanges. Once spackling is complete, remove the mud guards.

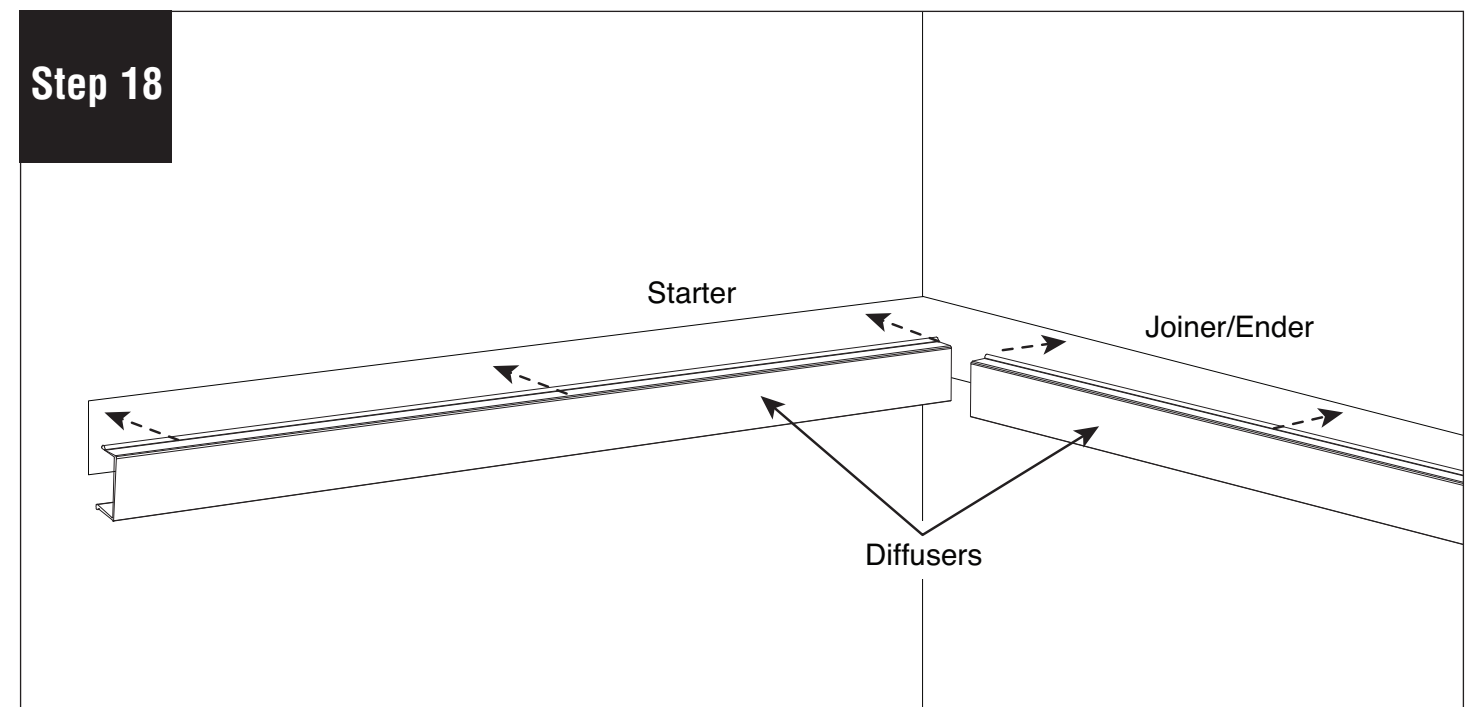

Replace diffusers and turn power on to luminaire.

**Note:** All power connections to be installed to local/national codes by a Certified Electrician.