

HP-2 Recessed Flush Diffuser Visible Flange Starter/Independent Installation Instructions

Scan QR code for helpful video(s)

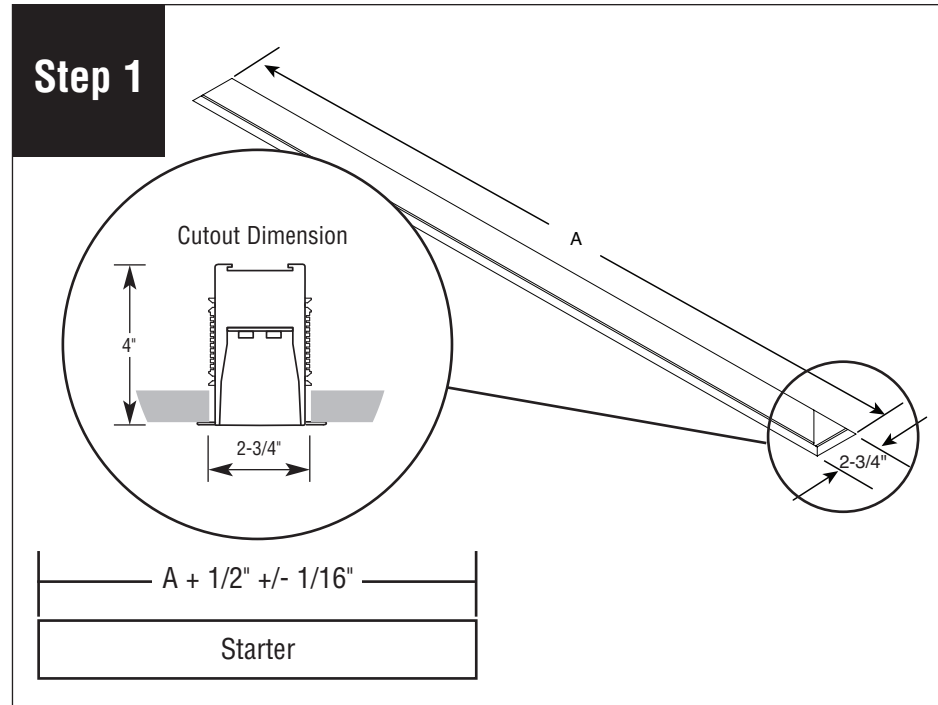

0 - 10V Dimming



Add 1/2" to body/row length (A), +/- 1/16" to simplify installation. Luminaire needs to be installed next to support blocking.

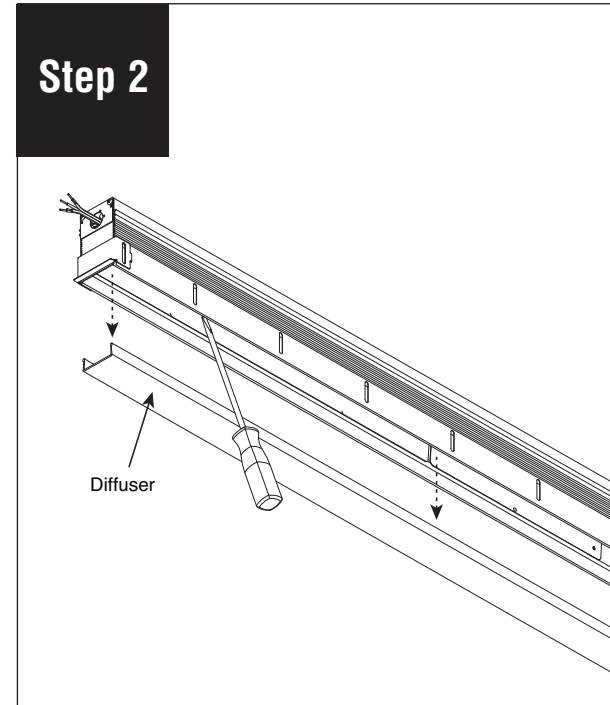

Remove diffuser and set aside to prevent it from getting dirty or damaged.

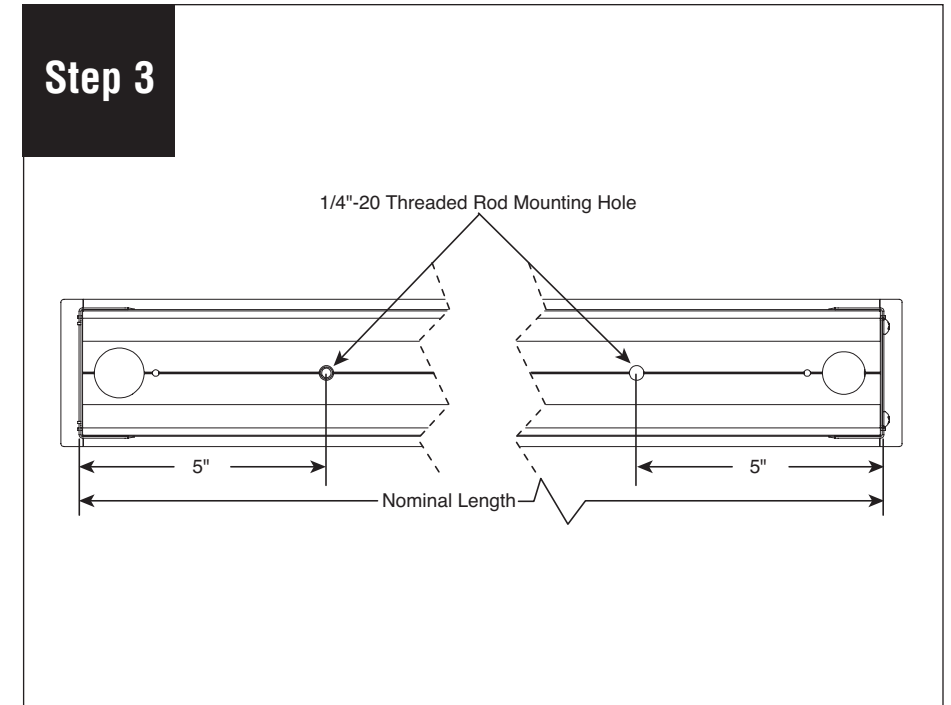

Refer to threads and feed hole locations above before connecting luminaire wires.

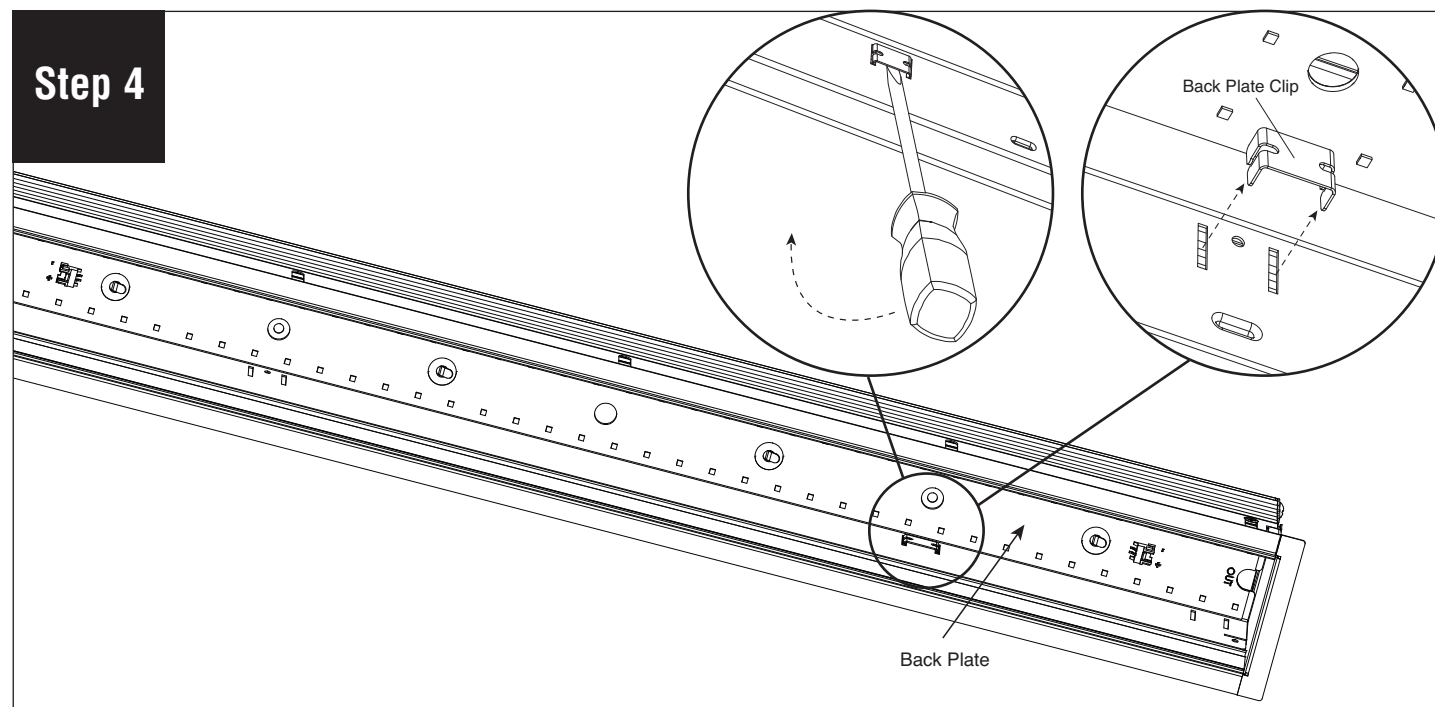

Remove back plate clips (provided) to release back plates. We recommend using a flat head screwdriver to get them loose. **CAUTION: Do not lose these pieces.**

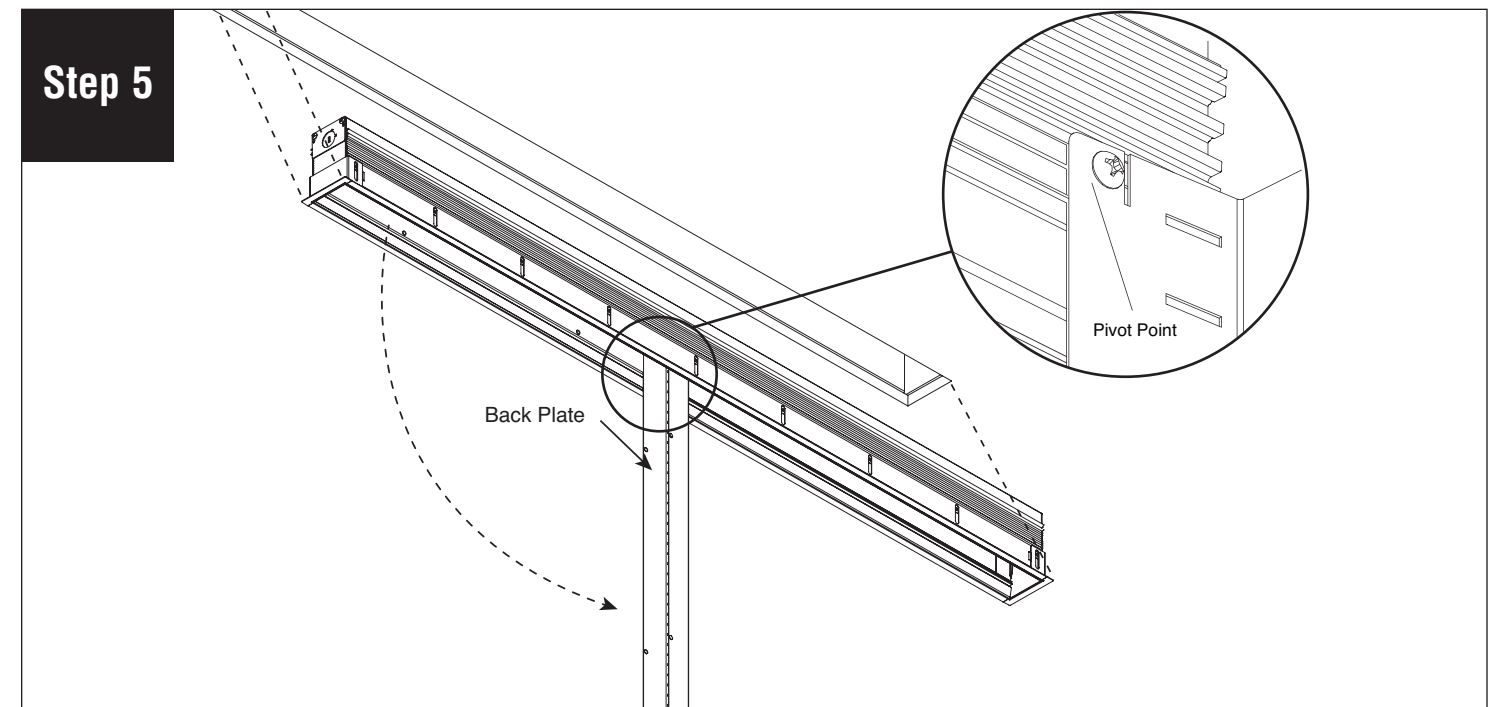

Align luminaire within rough opening in drywall and 1/4"-20 threaded rod. Slowly swing down back plates. **CAUTION: Do not twist back plate when swinging down - it will come out of the support extrusion.** Note that the screw shown is the pivot point and the back plate can be slid a few inches either way for ease of access to the driver space.

Note: All power connections to be installed to local/national codes by a Certified Electrician.

HP-2 Recessed Flush Diffuser Visible Flange Starter/Independent Installation Instructions

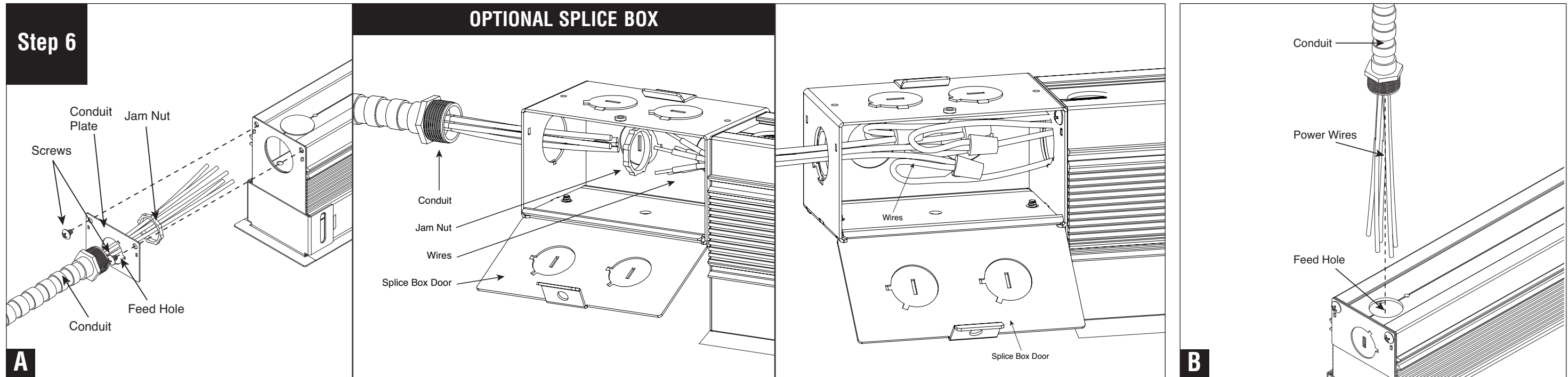

Remove jam nut from conduit then insert wires and connector through feed hole. Secure conduit with jam nut. **A.** Standard installation.

Open optional splice box door to access wiring.

Run power cable through knock-out. Make electrical connection. Secure conduit on to splice box with jam nut and close splice box door.

B. Alternate option from top.

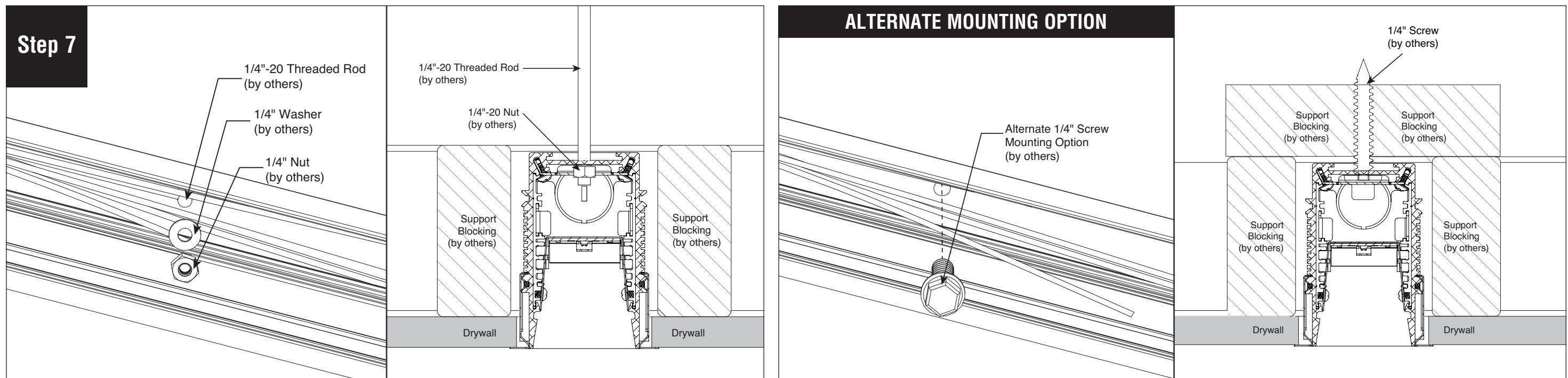

Install 1/4" washers (by others) and 1/4"-20 nuts (by others) onto 1/4"-20 threaded rod (by others).

Alternate mounting option - Install 1/4" screw (by others) through mounting hole into proper structurally supported blocking (by others).

Note: All power connections to be installed to local/national codes by a Certified Electrician.

HP-2 Recessed Flush Diffuser Visible Flange Starter/Independent Installation Instructions

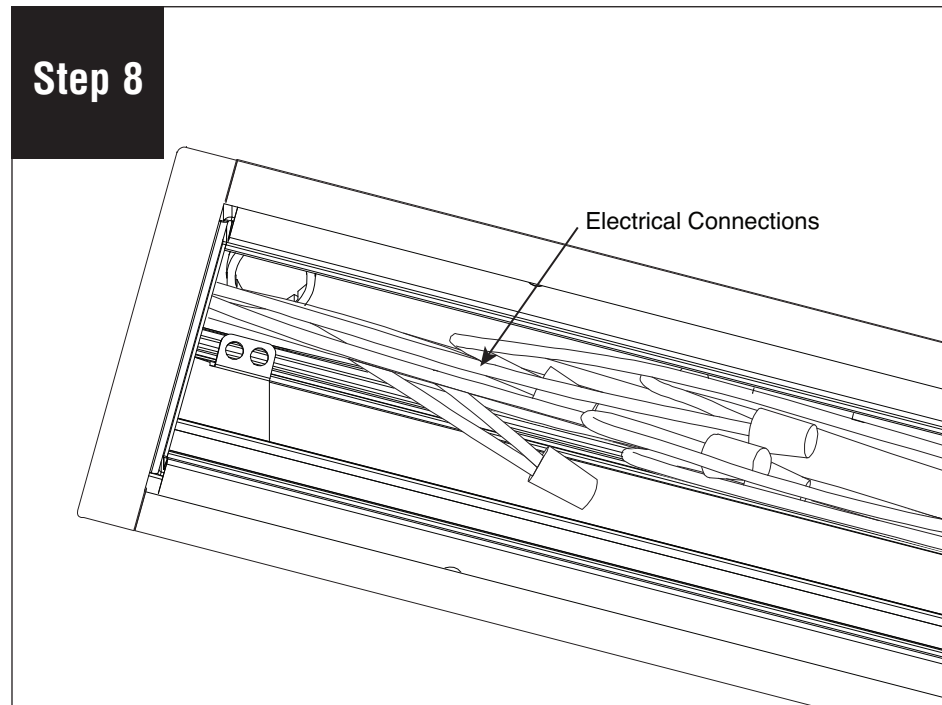

Make electrical connections.

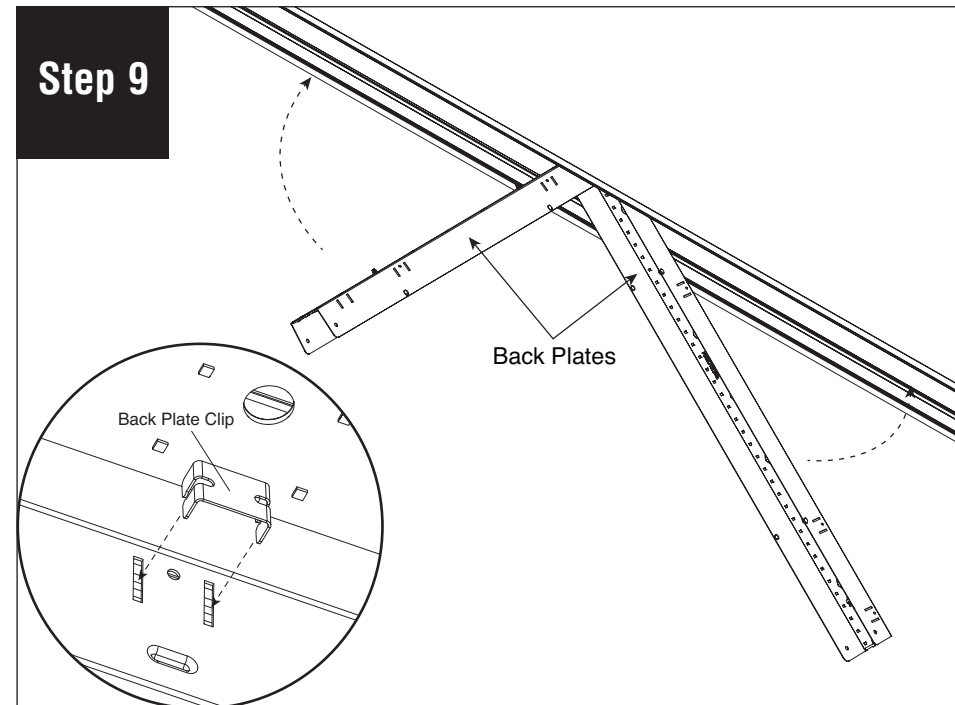

Replace back plates by holding them in their original position and pushing the clips back in. Make sure wire connections are not pinched. (If 1 ft. back plate assembly is near joint, reconnect feed harness to LED board.)

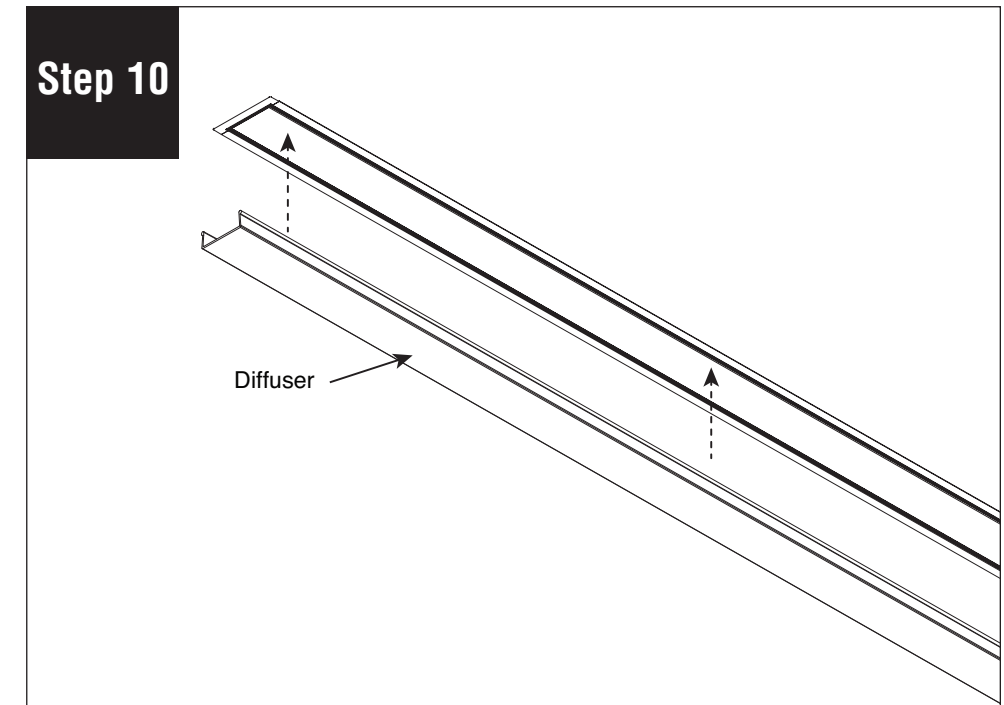

Reinstall diffuser and turn power on to luminaire.

Note: All power connections to be installed to local/national codes by a Certified Electrician.

HP-2 Recessed Flush Diffuser Visible Flange Joiner/Ender Installation Instructions

Scan QR code for helpful video(s)



0 - 10V Dimming

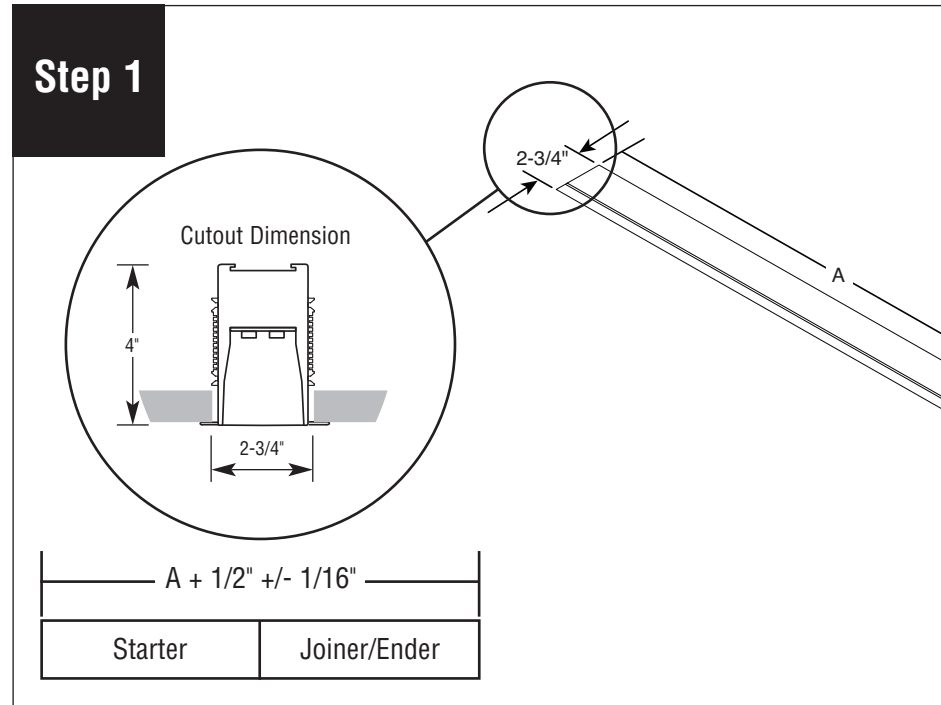

Add 1/2" to body/row length (A), +/- 1/16" to simplify installation. Luminaire needs to be installed next to support blocking.

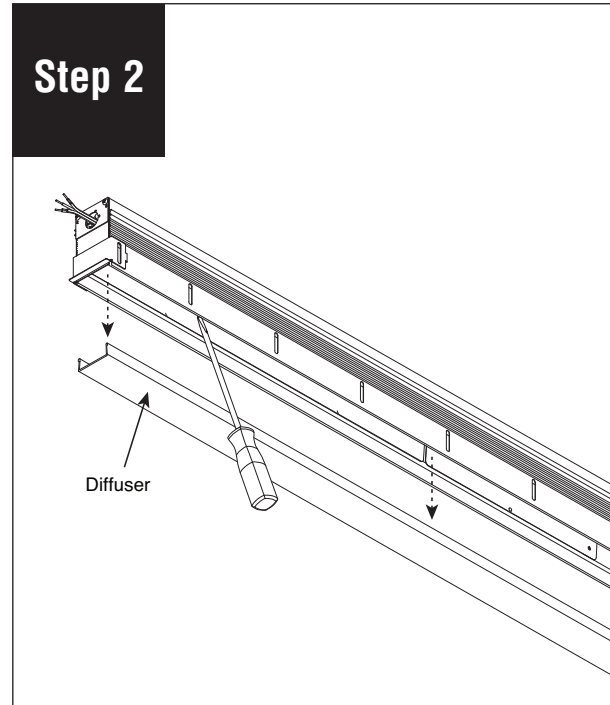

Remove diffuser and set aside to prevent it from getting dirty or damaged.

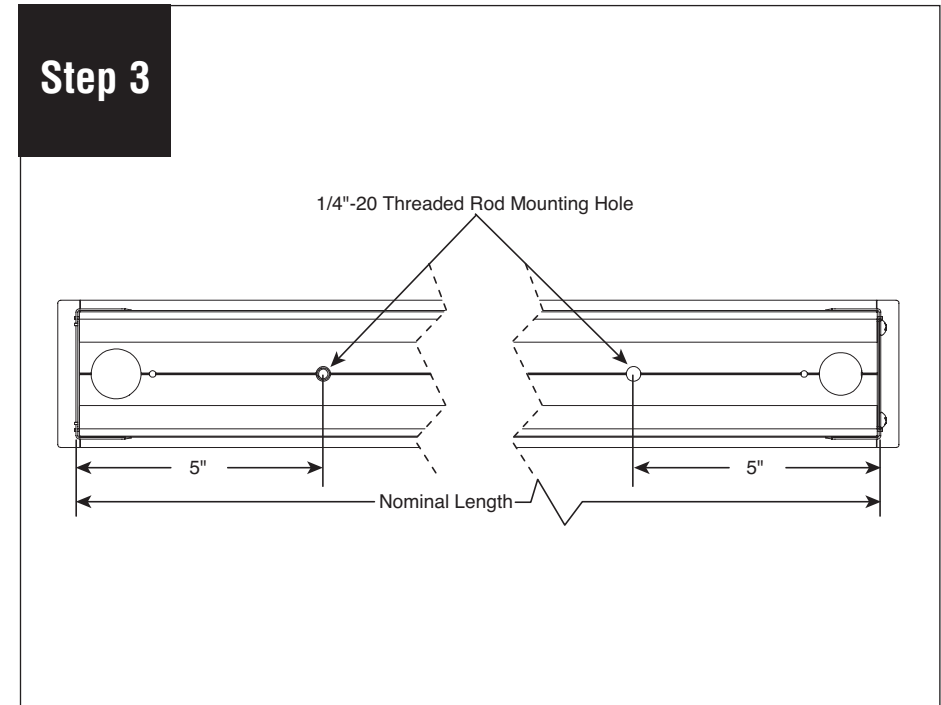

Refer to threads and feed hole locations above before connecting luminaire wires.

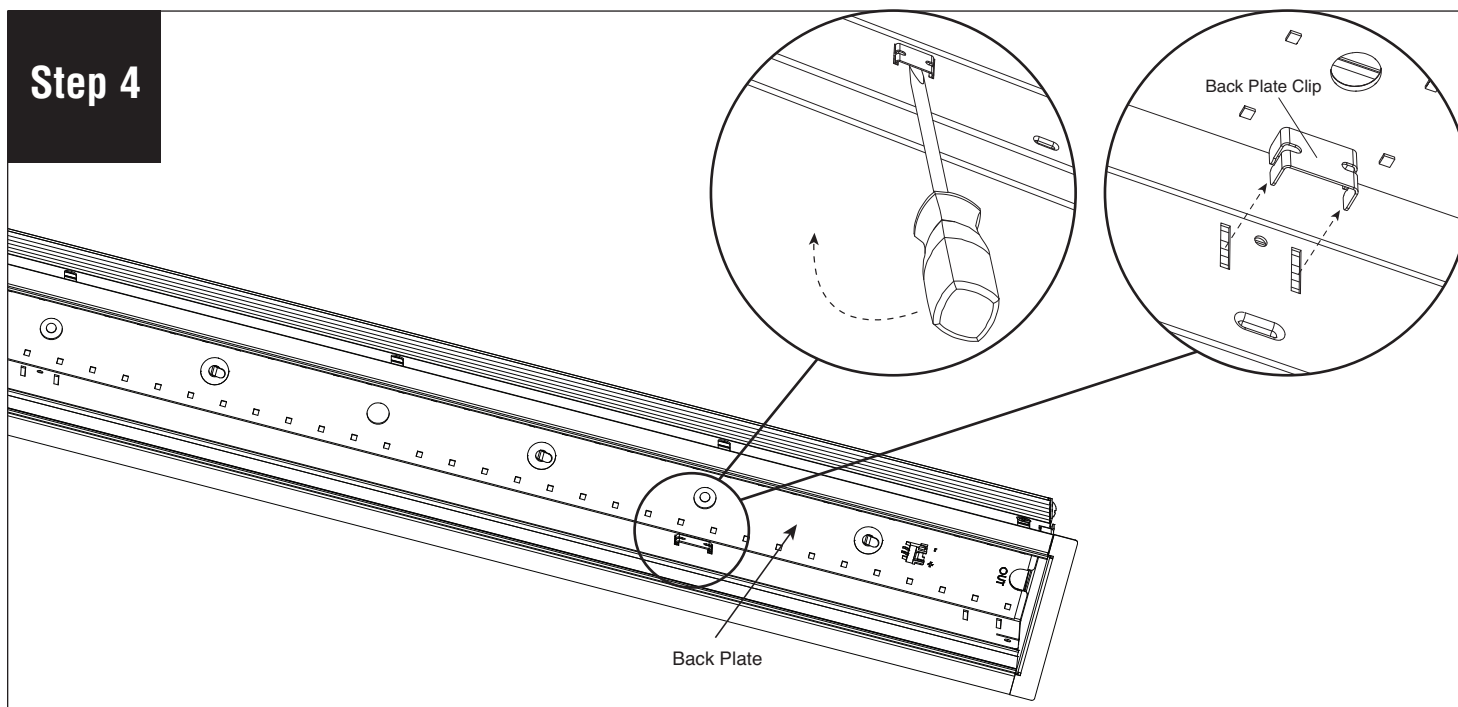

Remove back plate clips (provided) to release back plates. We recommend using a flat head screwdriver to get them loose. **CAUTION: Do not lose these pieces.**

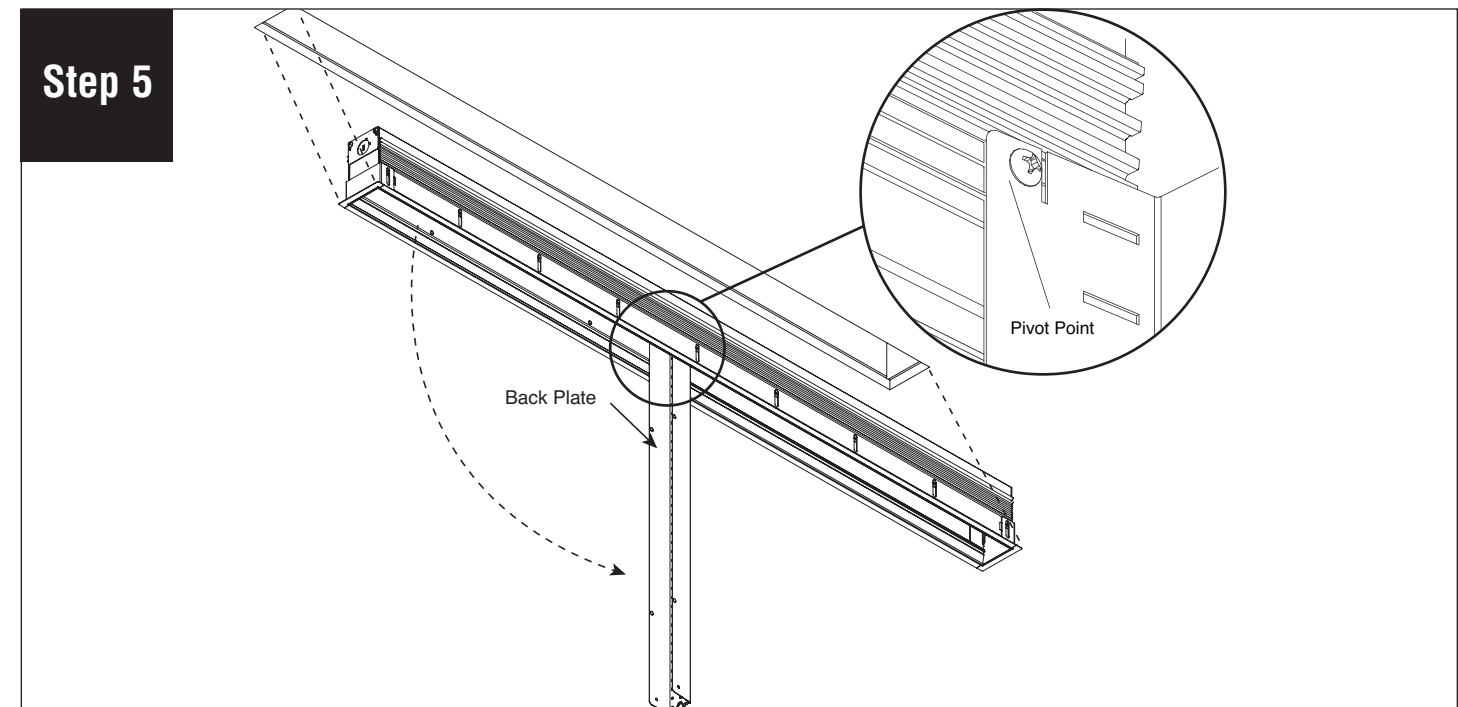

Align luminaire within rough opening in drywall and 1/4"-20 threaded rod. Slowly swing down back plates. **CAUTION: Do not twist back plate when swinging down - it will come out of the support extrusion.** Note that the screw shown is the pivot point and the back plate can be slid a few inches either way for ease of access to the driver space.

Note: All power connections to be installed to local/national codes by a Certified Electrician.

HP-2 Recessed Flush Diffuser Visible Flange Joiner/Ender Installation Instructions

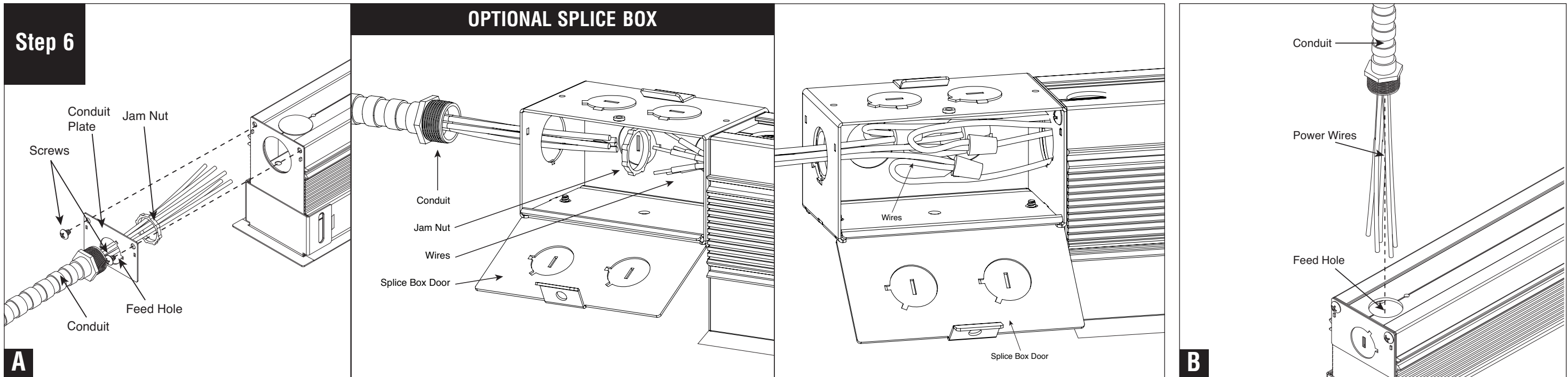

Remove jam nut from conduit then insert wires and connector through feed hole. Secure conduit with jam nut. **A.** Standard installation.

Open optional splice box door to access wiring.

Run power cable through knock-out. Make electrical connection. Secure conduit on to splice box with jam nut and close splice box door.

B. Alternate option from top.

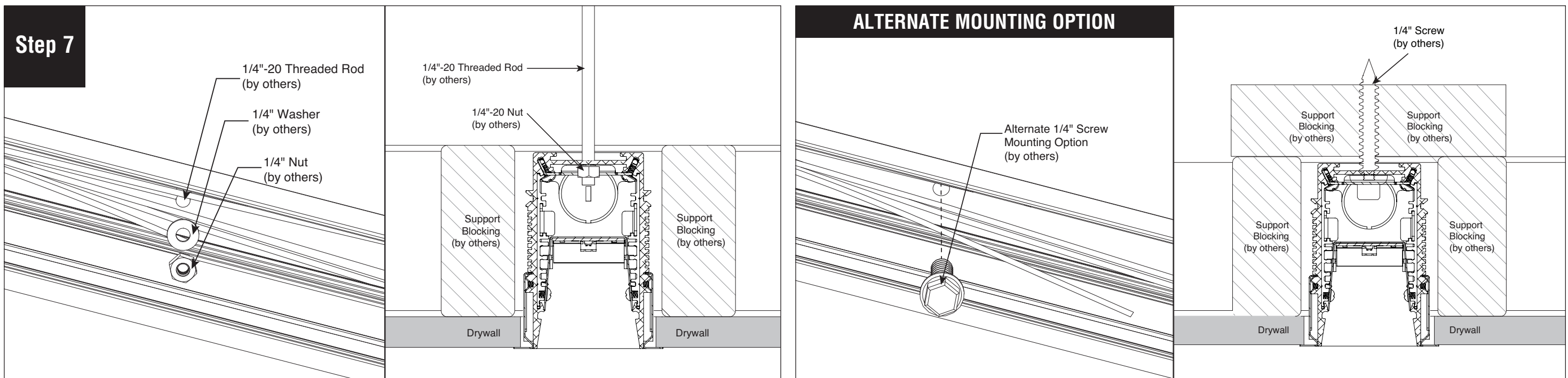

Install 1/4" washers (by others) and 1/4"-20 nuts (by others) onto 1/4"-20 threaded rod (by others). **When adding a joiner/ender, allow the luminaire to hang below ceiling while still having it supported by the threaded rod, washers and nuts.**

Alternate mounting option - Install 1/4" screw (by others) through mounting hole into proper structurally supported blocking (by others).

Note: All power connections to be installed to local/national codes by a Certified Electrician.

HP-2 Recessed Flush Diffuser Visible Flange Joiner/Ender Installation Instructions

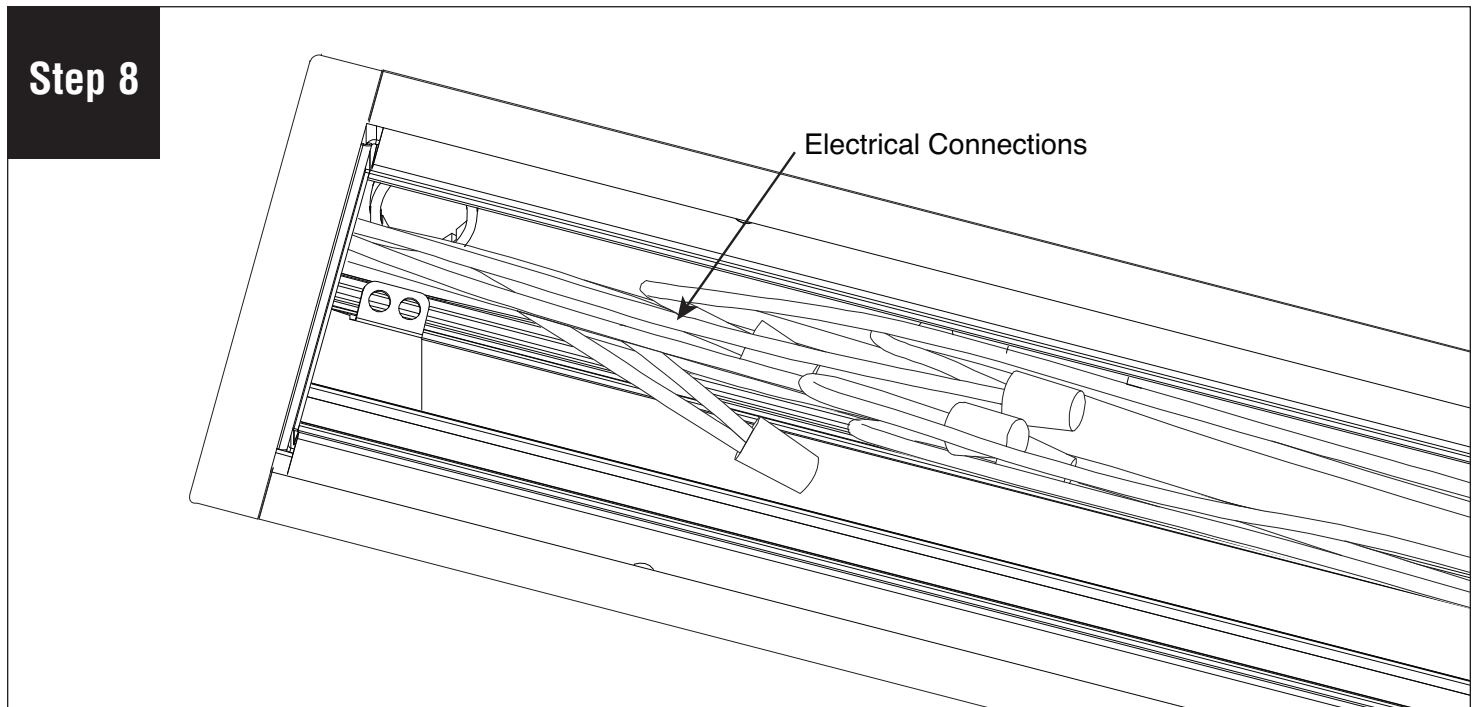

Make electrical connections

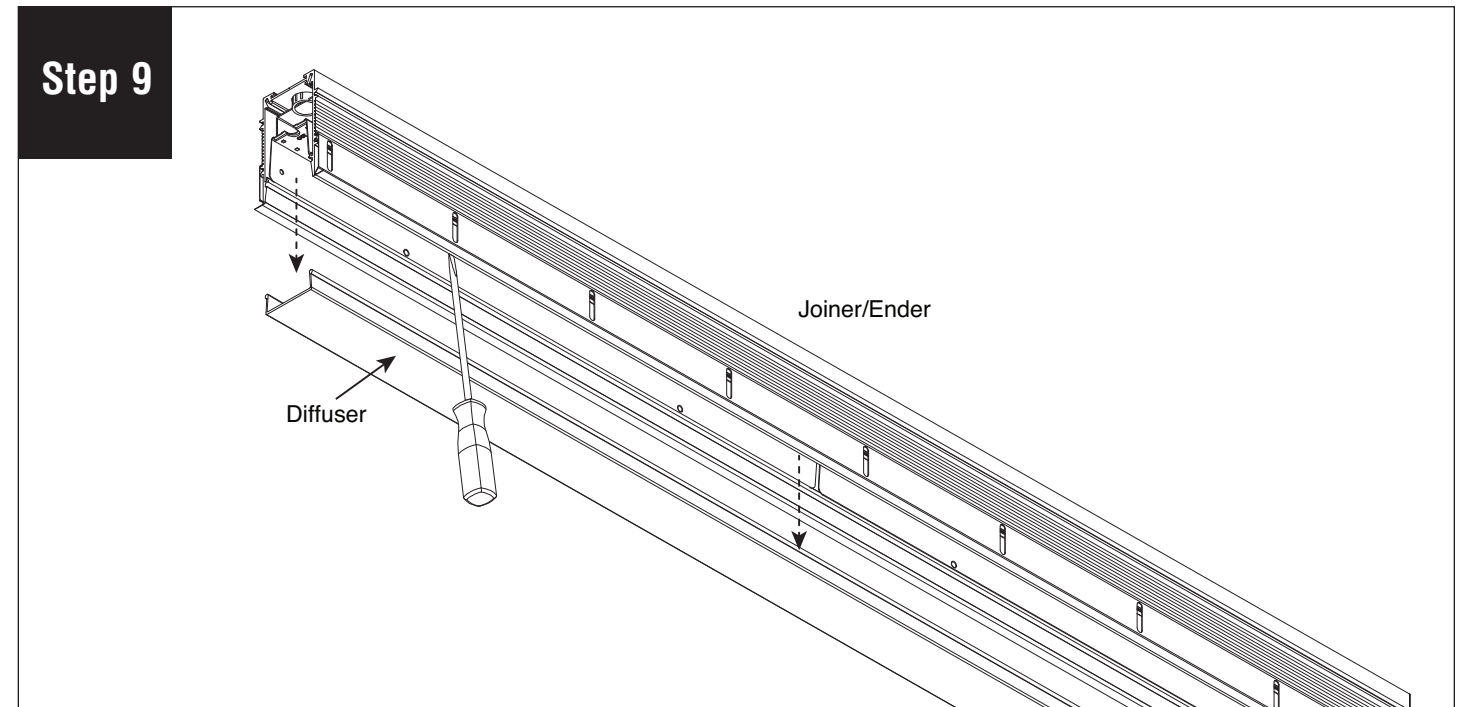

Remove diffuser from joiner/ender and set aside to prevent it from getting dirty or damaged.

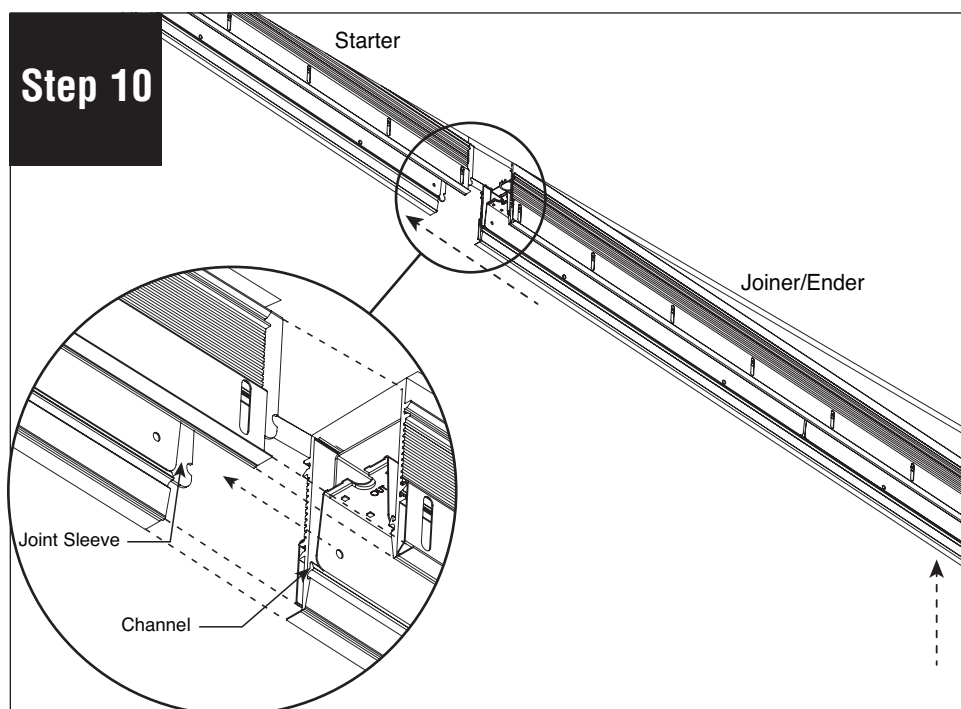

Slide joiner/ender against starter, then install into rough cut out. Align and insert joint sleeve with channel in body.

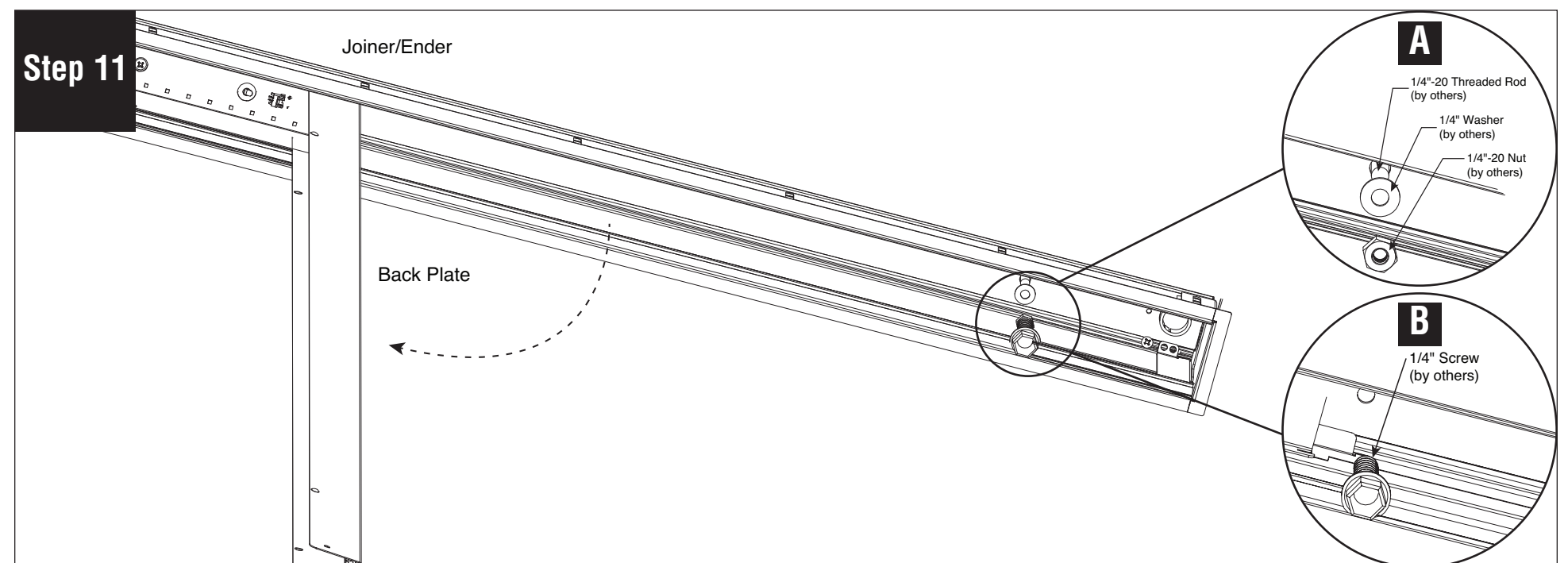

Open back plate from joiner/ender luminaire. **A.** Install 1/4" washers (by others) and 1/4"-20 nuts (by others) onto 1/4"-20 threaded rod (by others). **B.** Alternate mounting option - Install 1/4" screw (by others) through mounting hole into proper structurally supported blocking (by others). Refer to step 7 for details.

Note: All power connections to be installed to local/national codes by a Certified Electrician.

HP-2 Recessed Flush Diffuser Visible Flange Joiner/Ender Installation Instructions

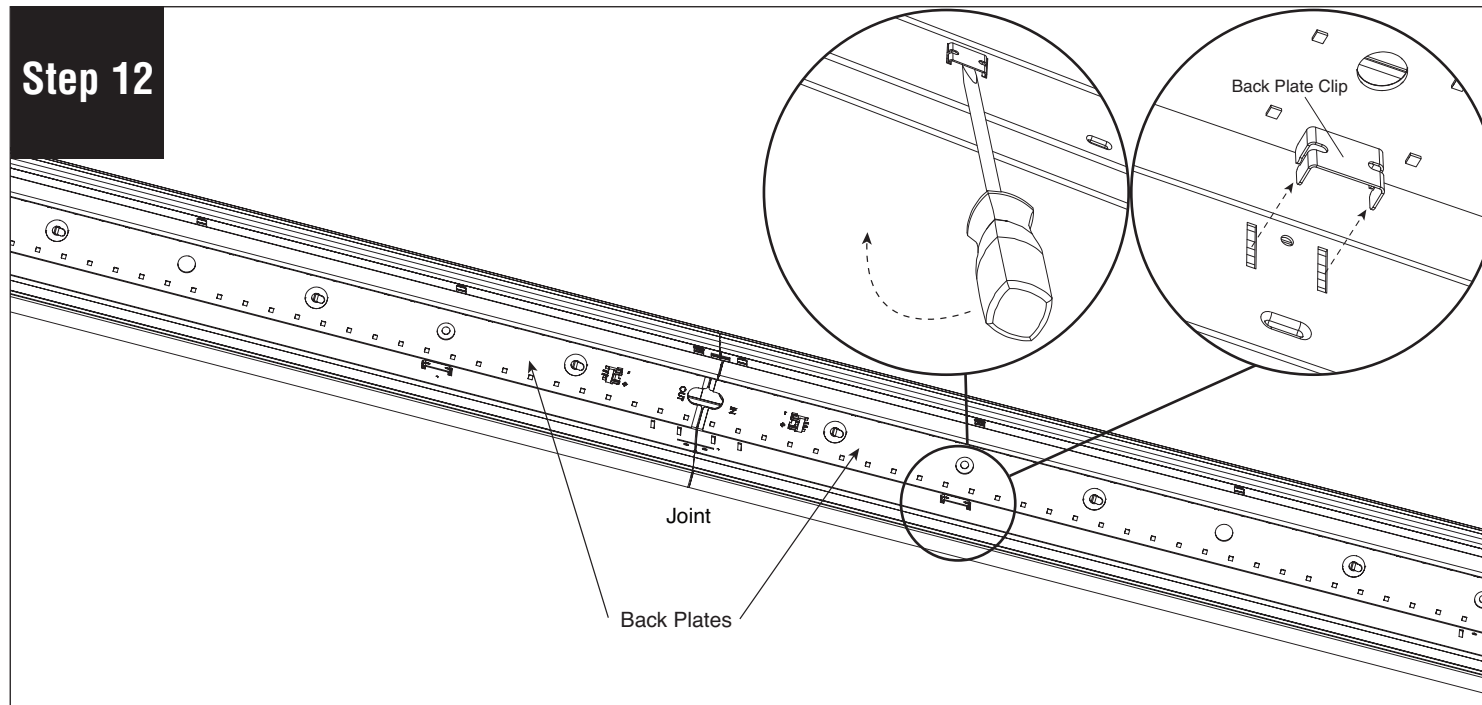

Remove back plate clips (provided) to release back plates at joint. We recommend using a flat head screwdriver to get them loose. **CAUTION: Do not lose these pieces.**

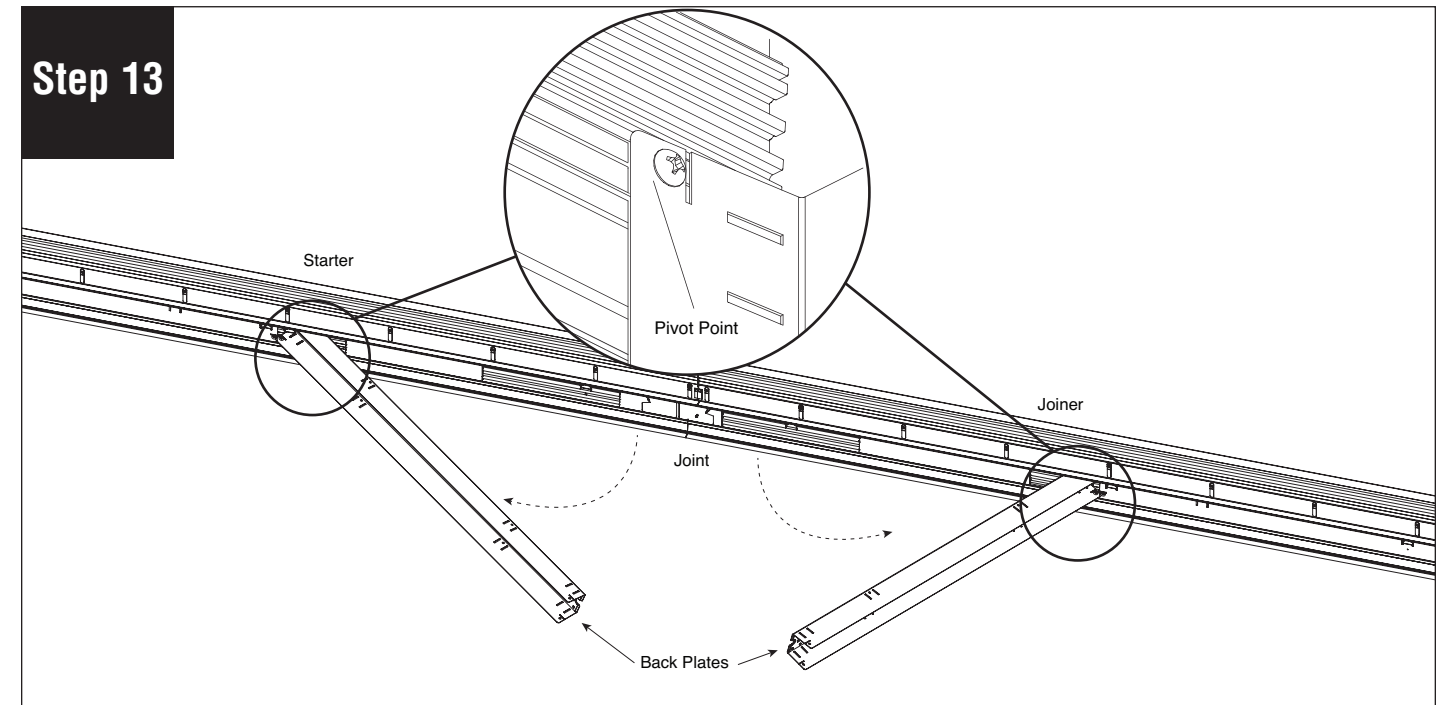

Slowly swing down back plates. **CAUTION: Do not twist back plate when swinging down - it will come out of the support extrusion.** Note that the screw shown is the pivot point and the back plate can be slid a few inches either way for ease of access to the driver space.

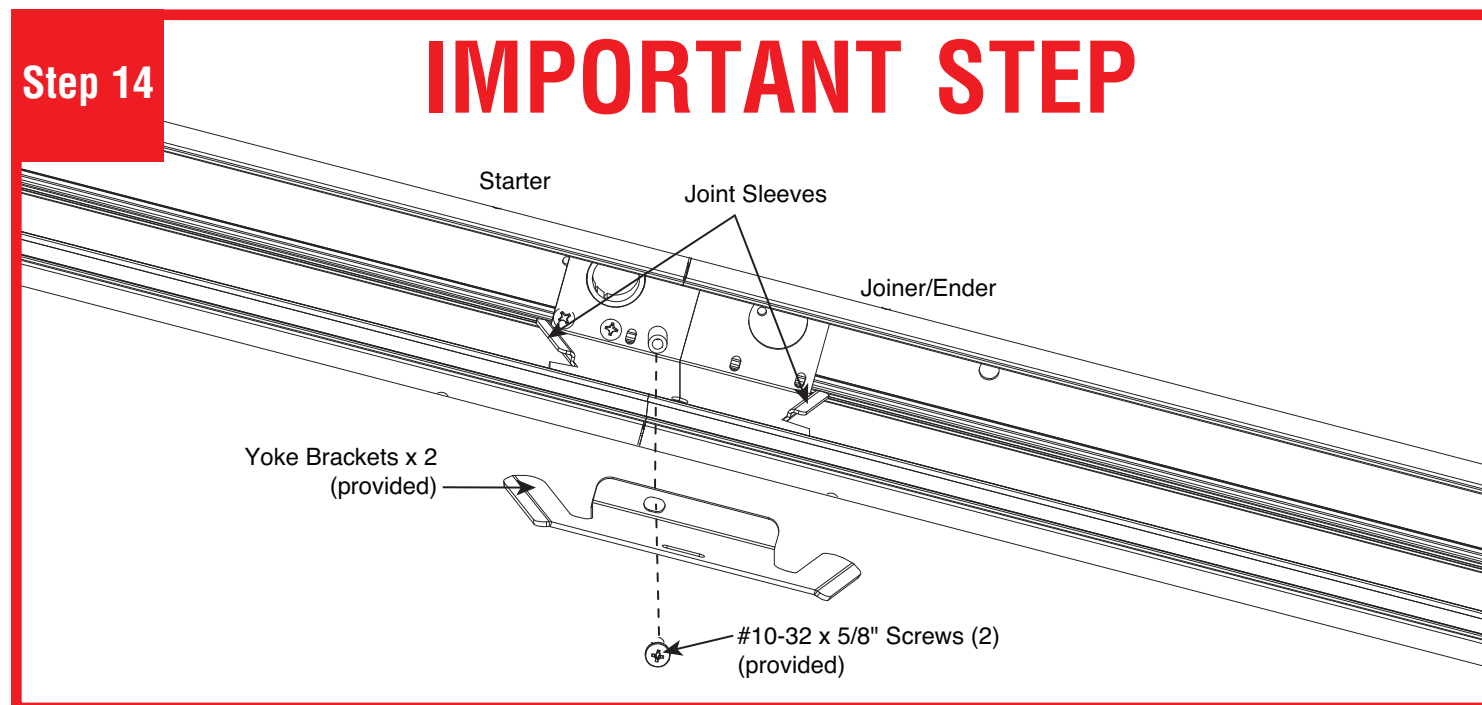

IMPORTANT STEP: Secure joint with two yoke brackets (provided) using #10-32 x 5/8" screws (provided). **CAUTION:** When installed correctly these brackets will pull luminaires together to make a tight joint. Do not over-tighten.

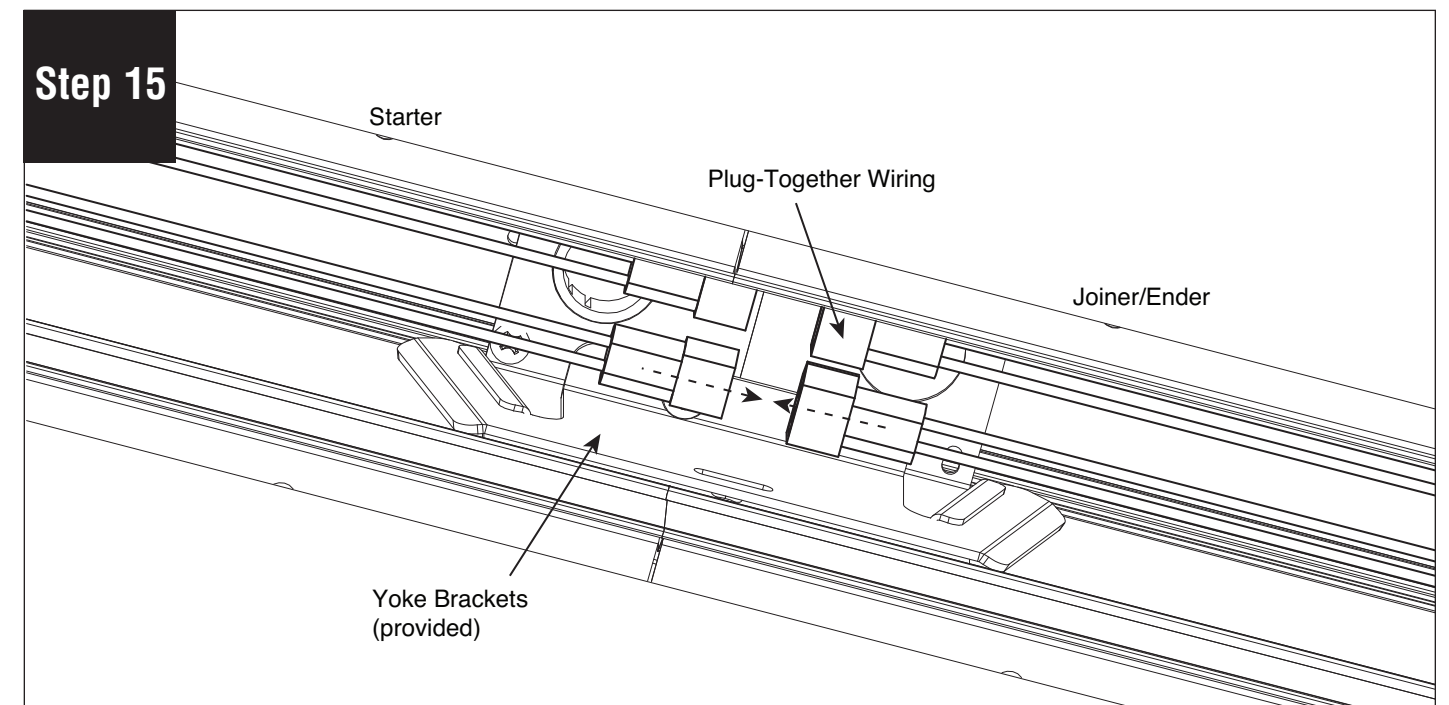

Connect plug-together wiring.

Note: All power connections to be installed to local/national codes by a Certified Electrician.

HP-2 Recessed Flush Diffuser Visible Flange Joiner/Ender Installation Instructions

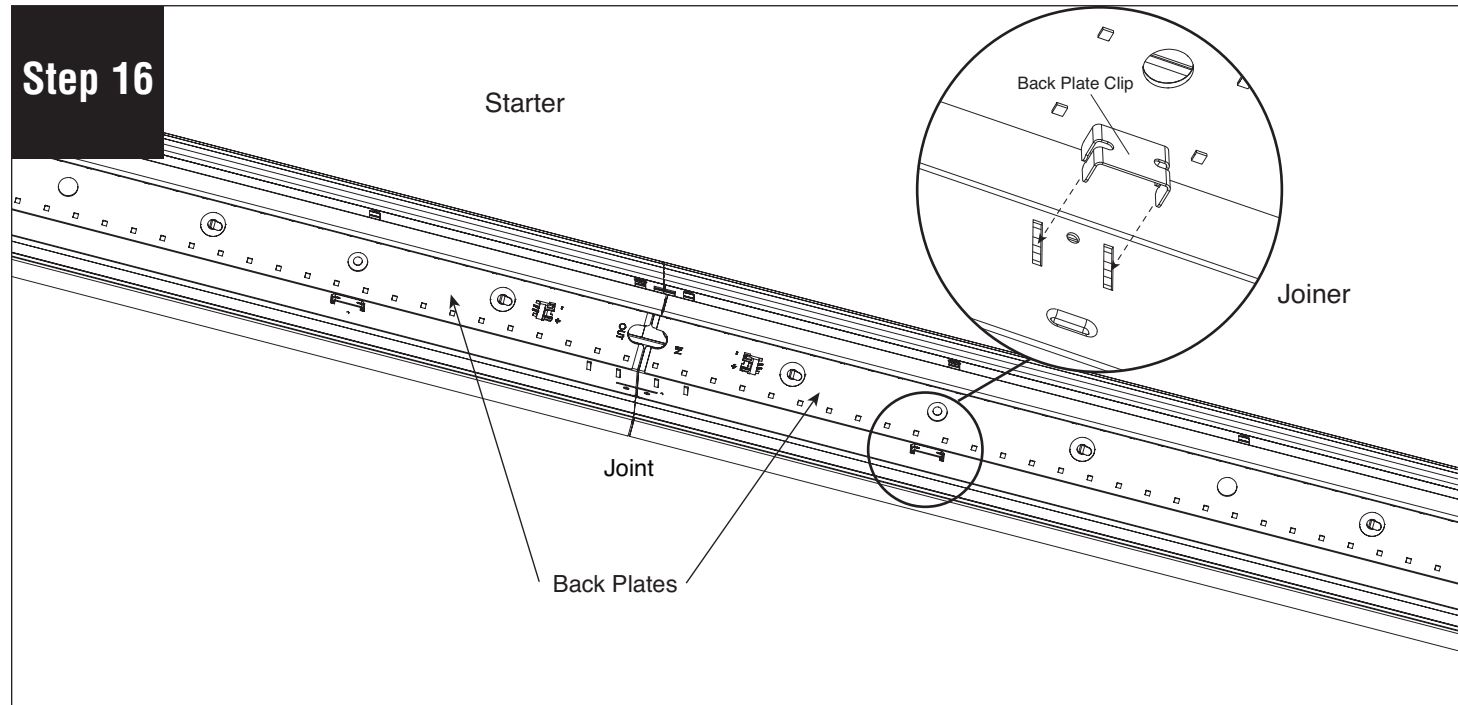

Replace all back plates by holding them in their original position and pushing the clips back in. Make sure wire connections are not pinched. (If 1 ft. back plate assembly is near joint, reconnect feed harness to LED board.)

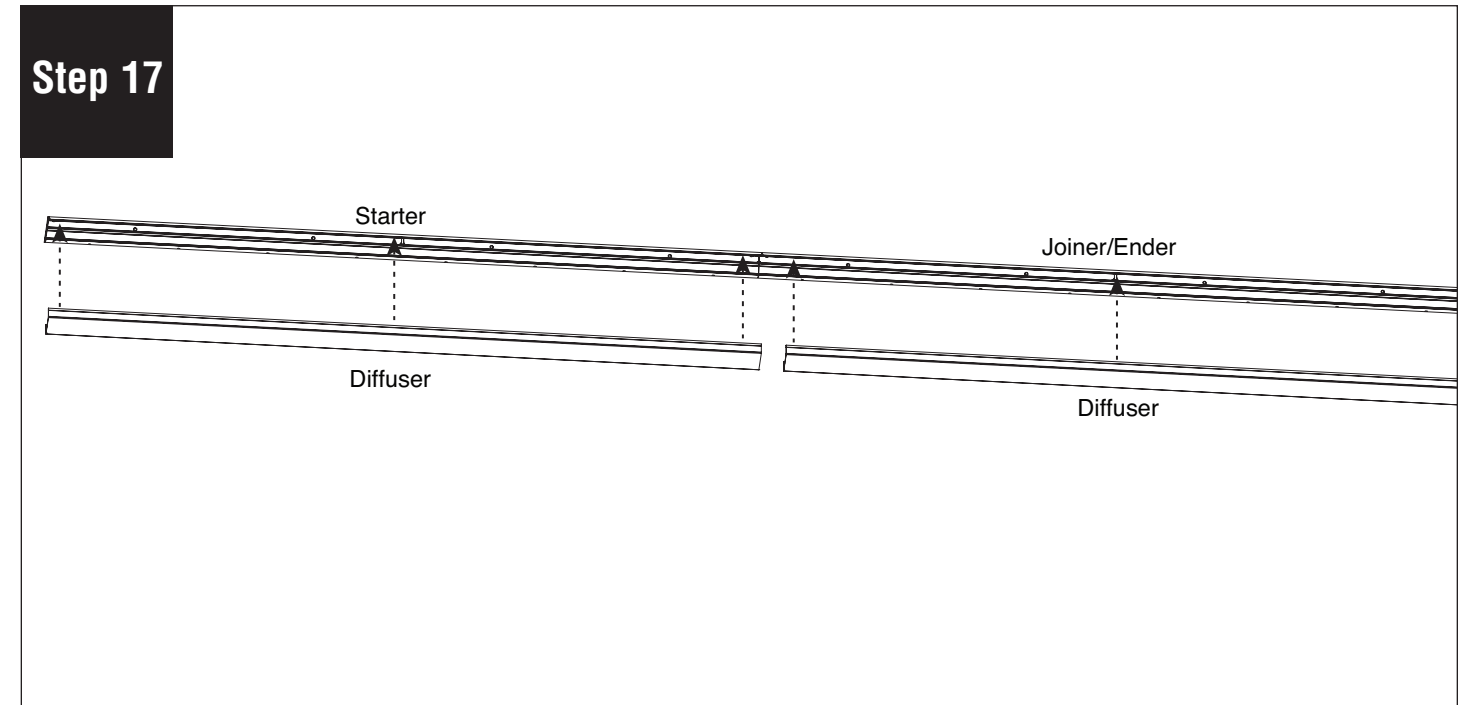

Replace diffusers and turn power on to luminaire.

Note: All power connections to be installed to local/national codes by a Certified Electrician.