

HP-4 Recessed 1" T-Bar to Spackle Flange Installation Instructions

Scan QR code for helpful video(s)



0 - 10V Dimming

Step 1

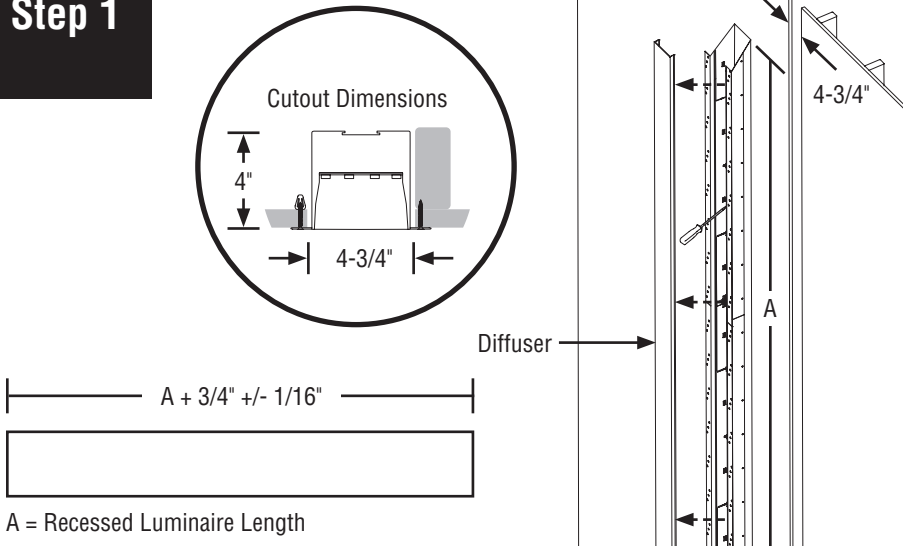

Remove diffuser from recessed spackle flange luminaire and set aside to prevent it from getting dirty or damaged. For recessed spackle flange rough opening, add 3/4" to the body/row length of the luminaire and +/- 1/16" to simplify installation. Luminaire needs to be installed next to support blocking.

Step 2

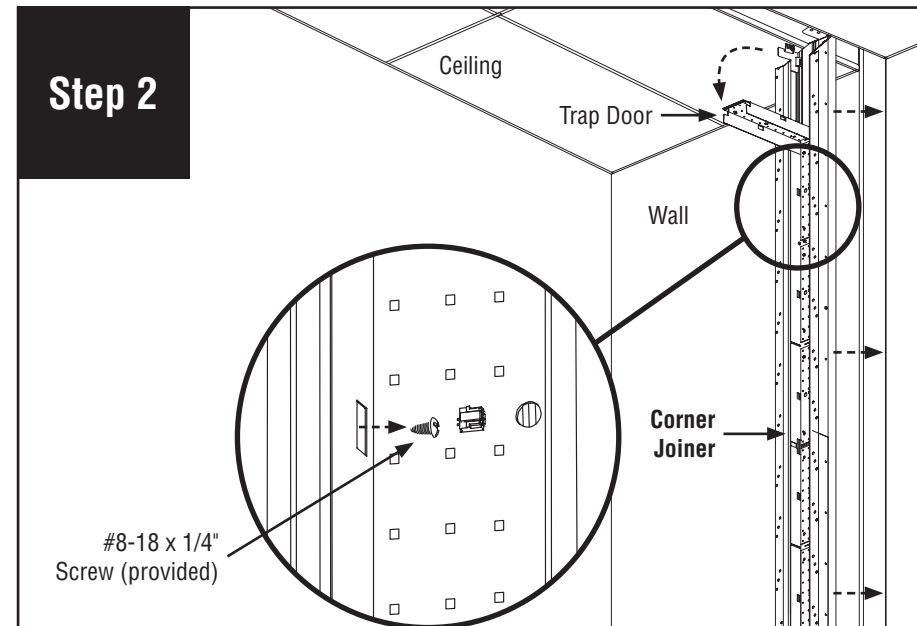

Remove #8-18 x 1/4" screw (provided) to open corner joiner trap door and then insert luminaire into wall rough opening. Use proper support blocking (by others).

Step 3

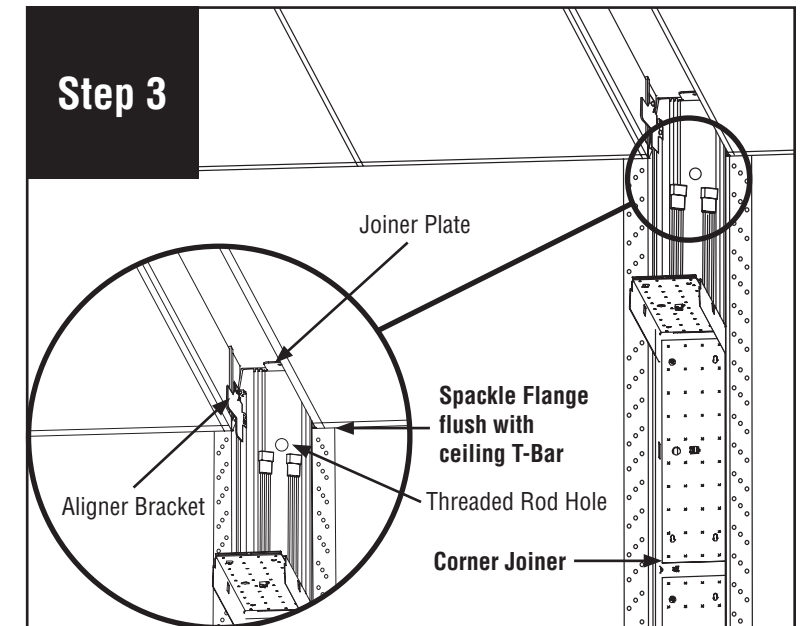

Make sure spackle flange is flush with ceiling T-Bar.

Step 4

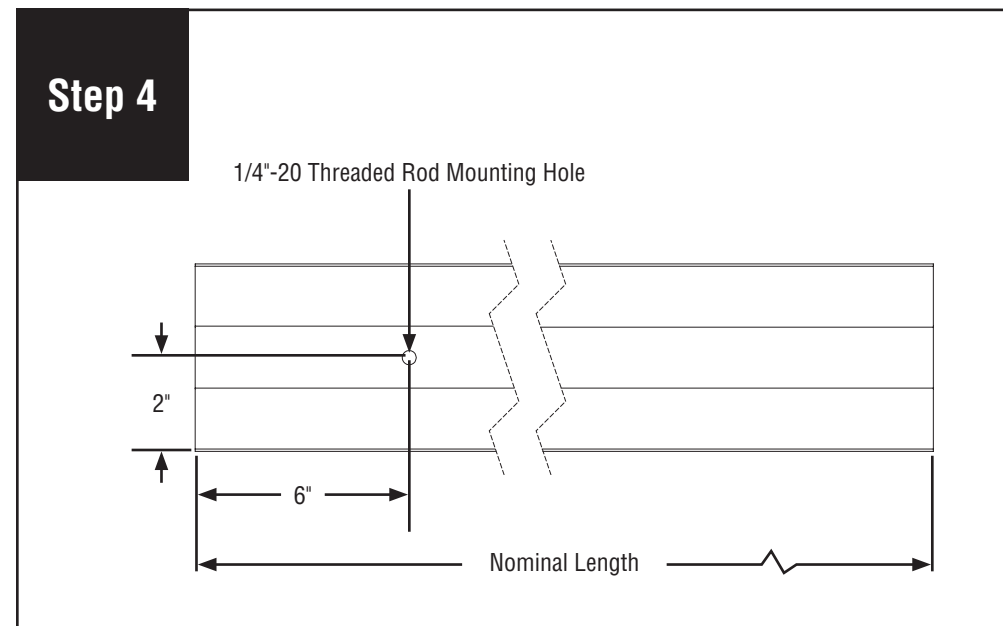
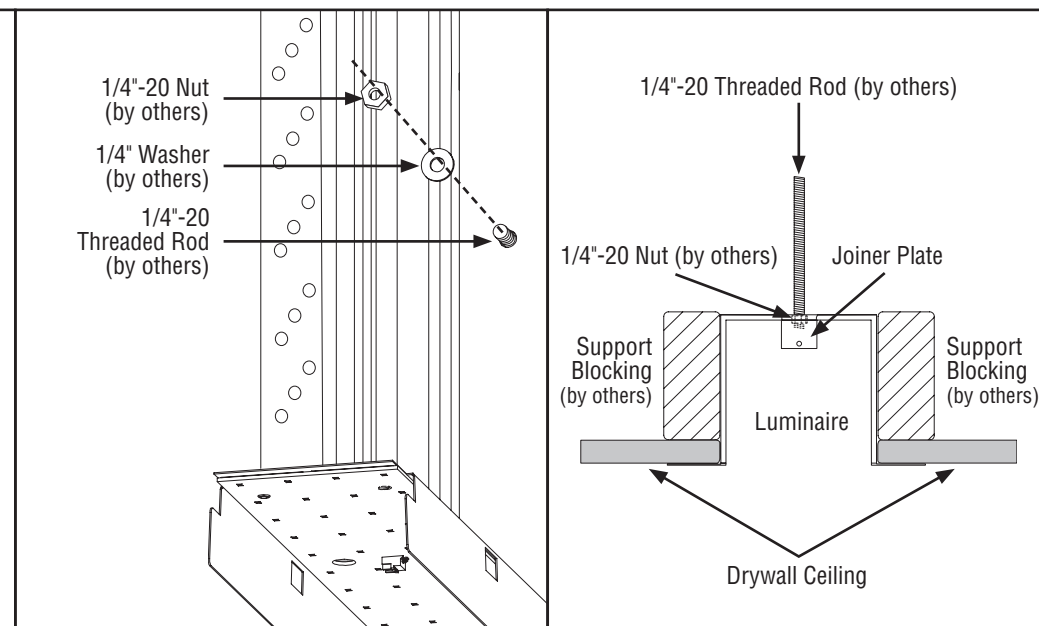
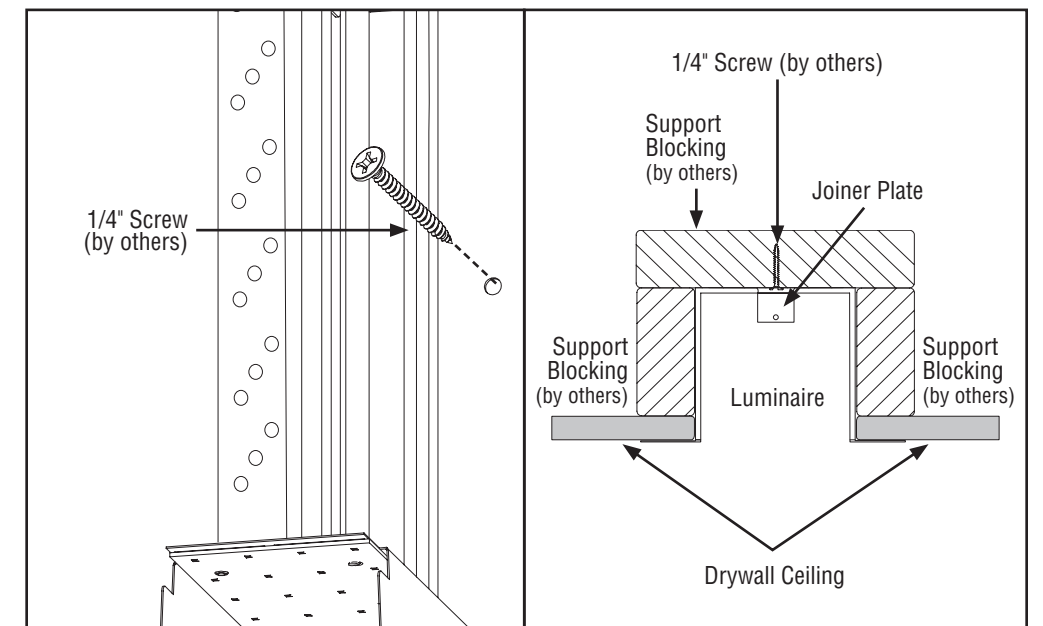
Secure luminaire to structure by using proper support (by others). Install 1/4" washers (by others) and 1/4"-20 nuts (by others) onto 1/4"-20 threaded rod (by others), or use alternate mounting options (use fastener and washer compatible to structural blocking to secure luminaire).

Note: All power connections to be installed to local/national codes by a Certified Electrician.

HP-4 Recessed 1" T-Bar to Spackle Flange Installation Instructions

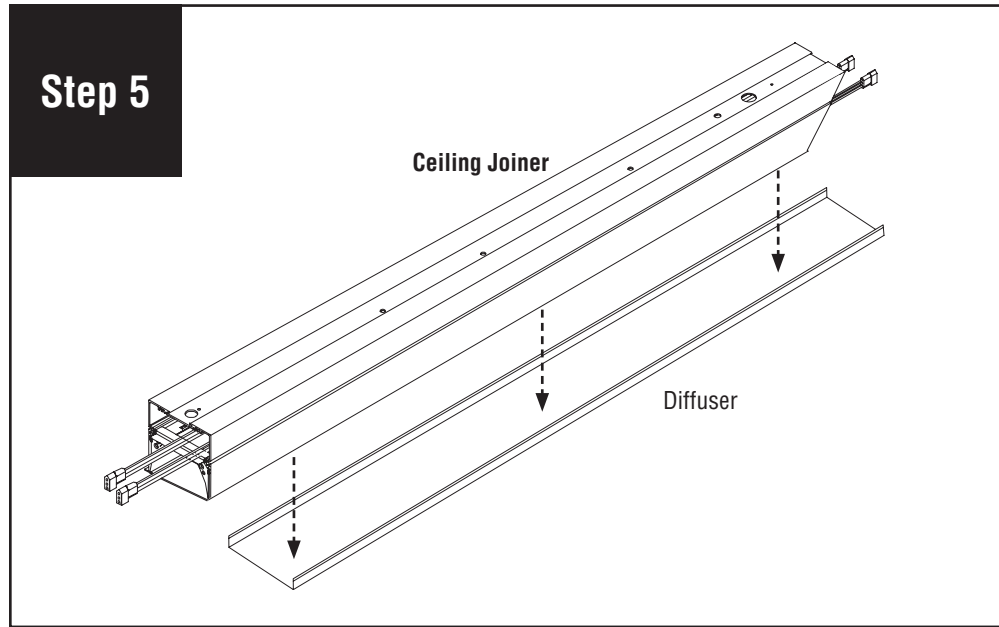

Remove diffuser from recessed 1" T-Bar joiner luminaire and set aside to prevent it from getting dirty or damaged. **NOTE:** If part of a longer run, diffuser will be reinstalled back into original luminaire section as lengths vary.

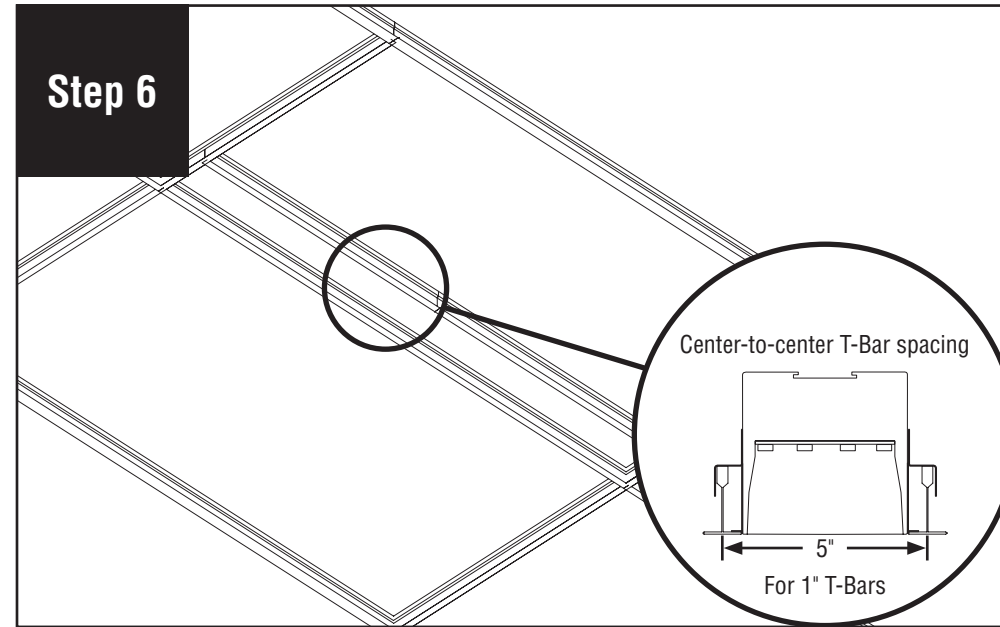

Configure T-Bar to luminaire size and leave an opening for luminaire. As noted above.

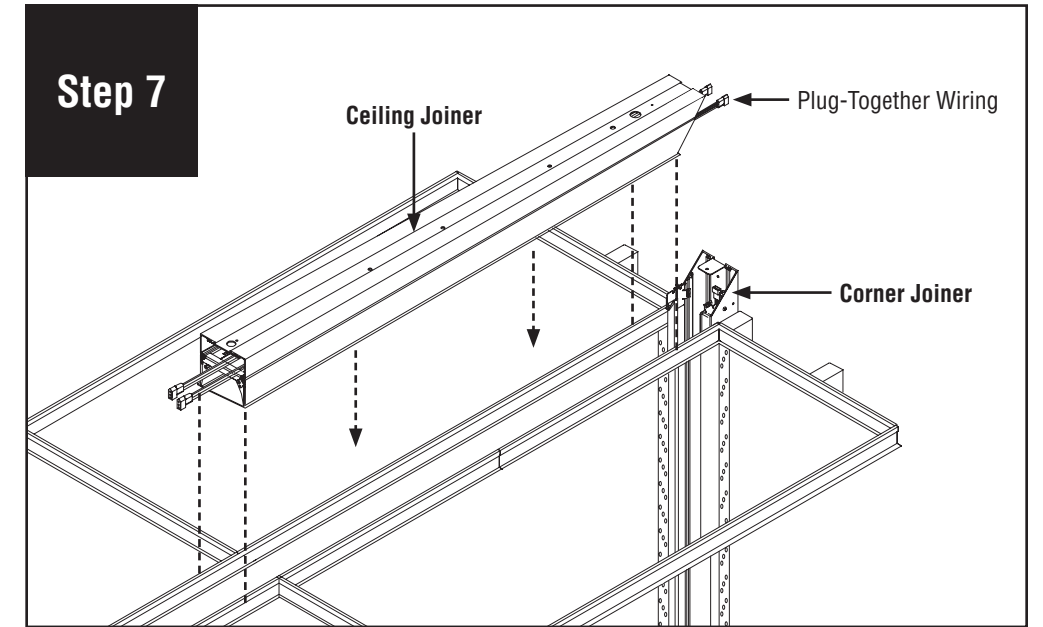

Place ceiling joiner luminaire on T-Bar.

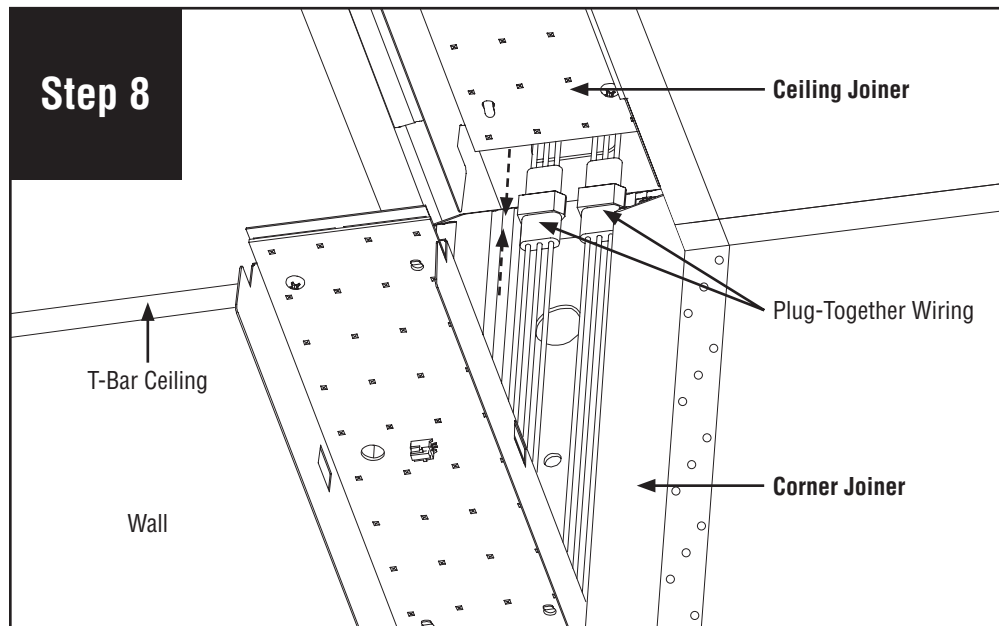

Connect plug-together wiring.

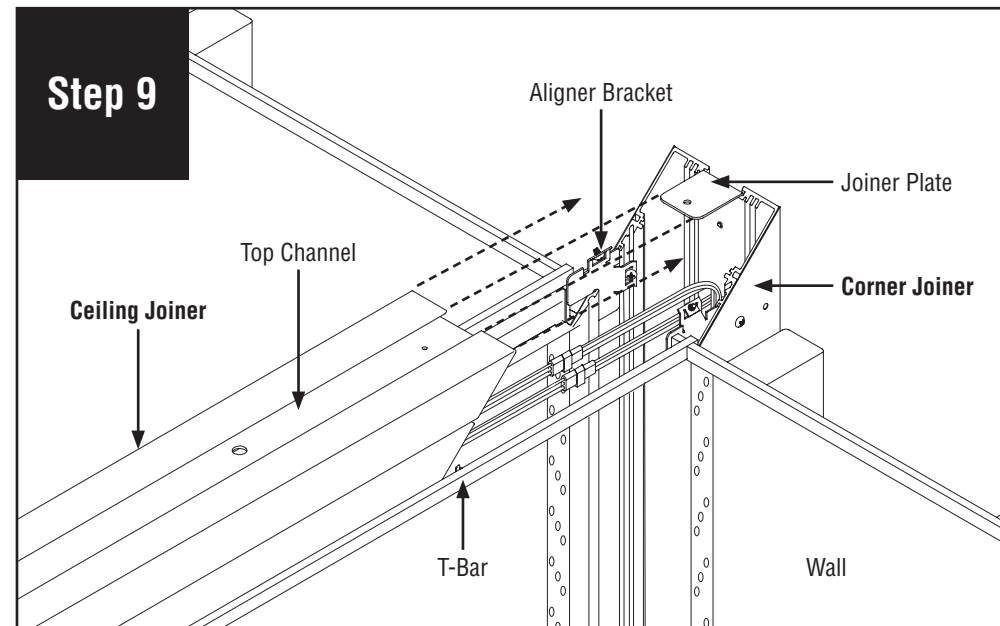

Slide ceiling joiner towards corner joiner. Align joiner plate with top channel.

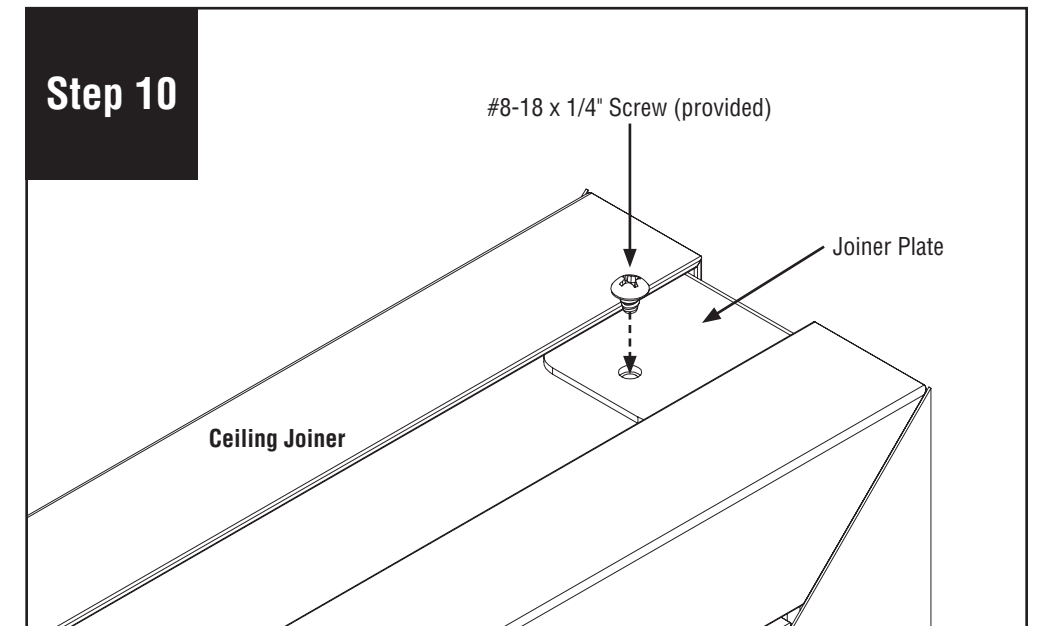

Install #8-18 x 1/4" screw (provided) onto joiner plate.

Note: All power connections to be installed to local/national codes by a Certified Electrician.

HP-4 Recessed 1" T-Bar to Spackle Flange Installation Instructions

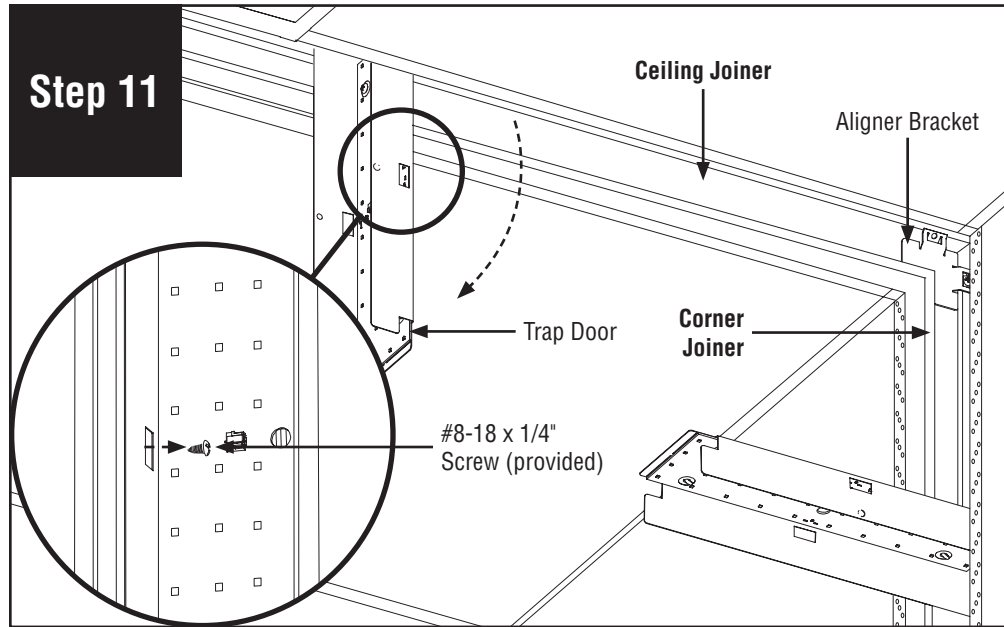

Remove #8-18 x 1/4" screw (provided) to open ceiling joiner trap door.

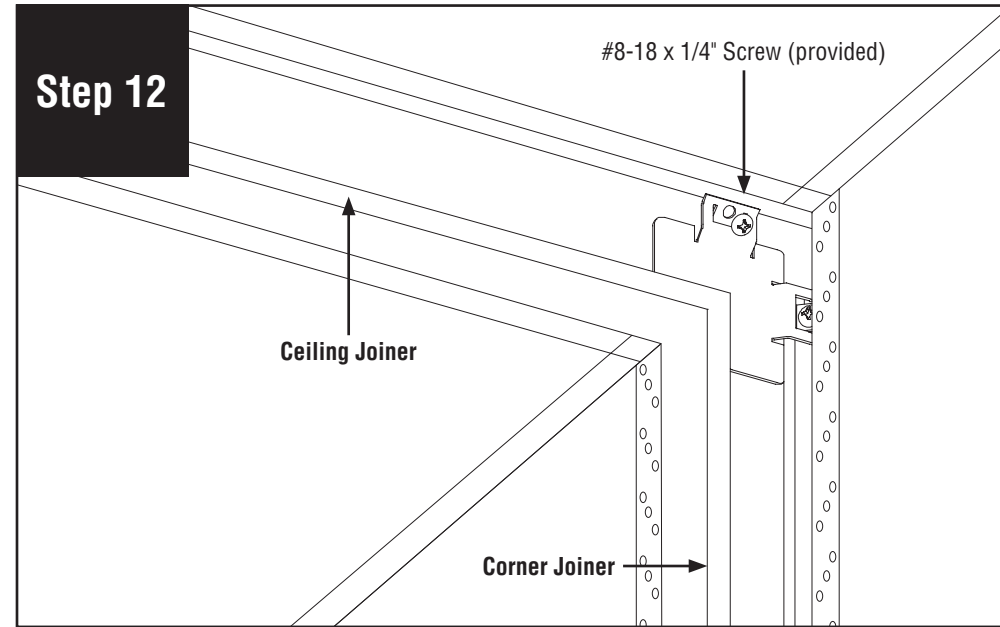

Install #8-18 x 1/4" screw (provided) into aligner brackets.

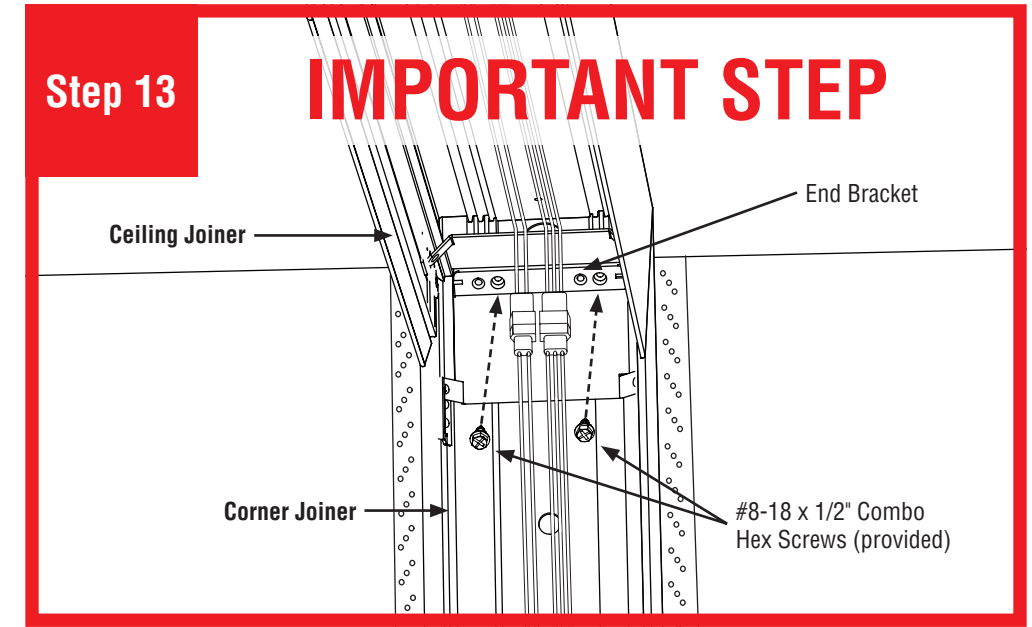

IMPORTANT STEP: Install 2 #8-18 x 1/2" combo hex screws (provided) into end bracket as shown. Screws can be installed from the left or right. **CAUTION: Do not over-tighten.**

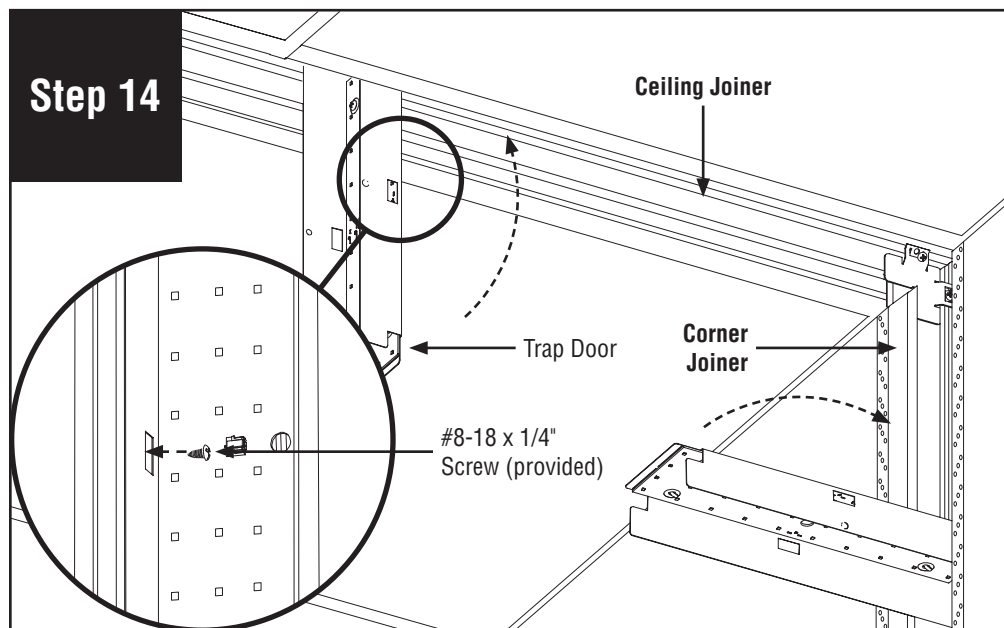

Close trap doors and fasten with #8-18 x 1/4" screws (provided).

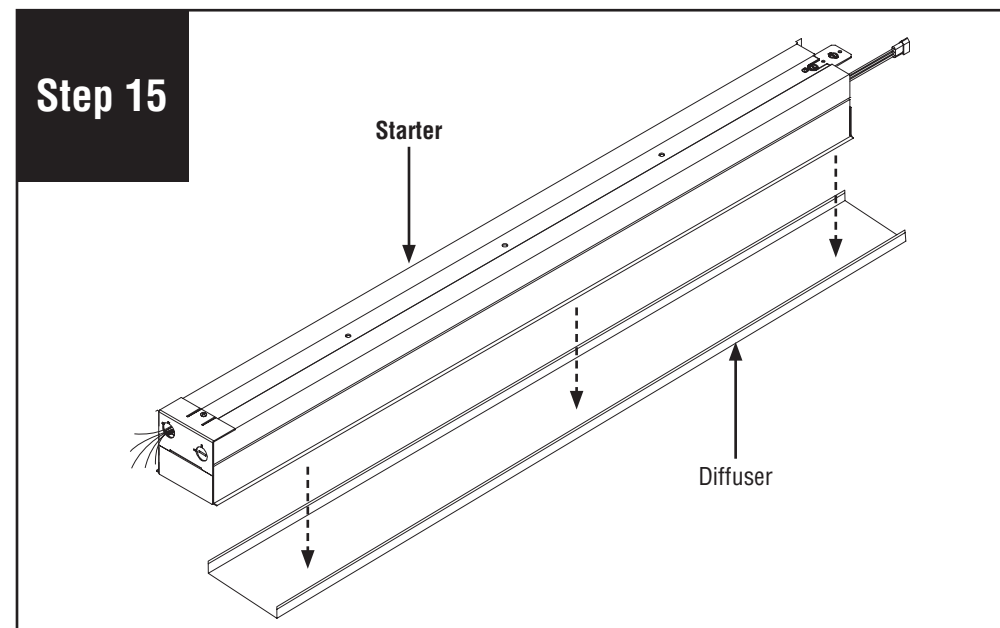

Remove diffuser from starter and set aside to prevent it from getting dirty or damaged.
NOTE: If part of a longer run, diffuser will be reinstalled back into original luminaire section as lengths vary.

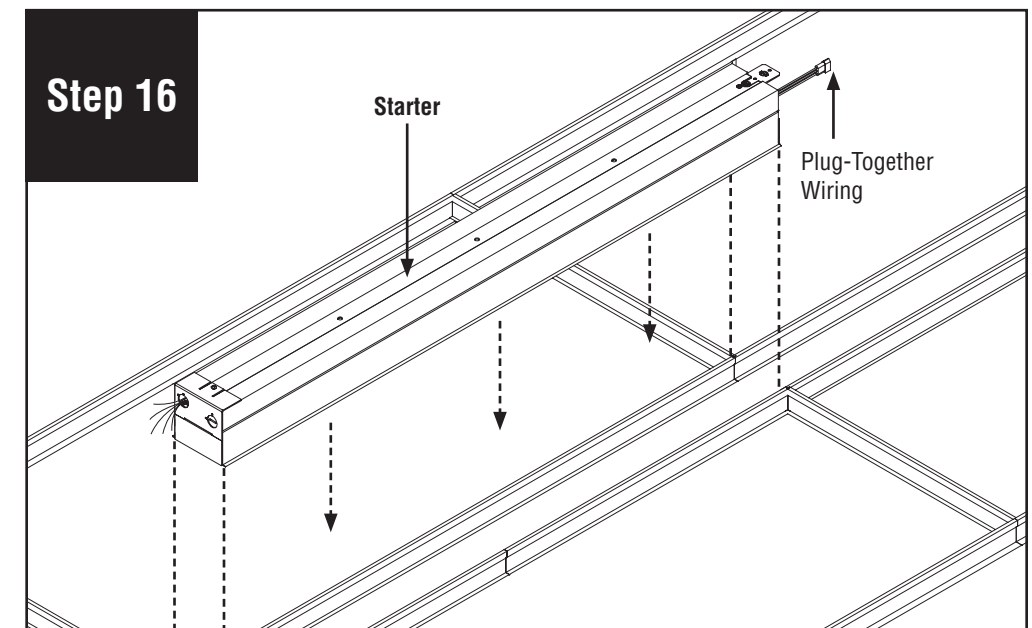

Place starter luminaire on T-Bar.

Note: All power connections to be installed to local/national codes by a Certified Electrician.

HP-4 Recessed 1" T-Bar to Spackle Flange Installation Instructions

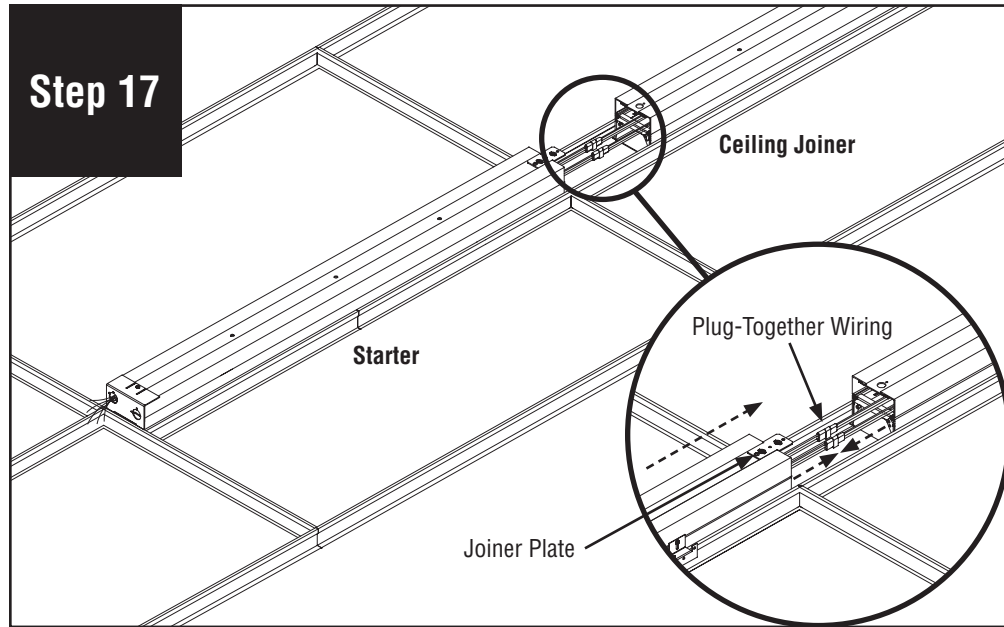

Connect plug-together wiring and align ceiling joiner with joiner plate and carefully slide starter and ceiling joiner together.

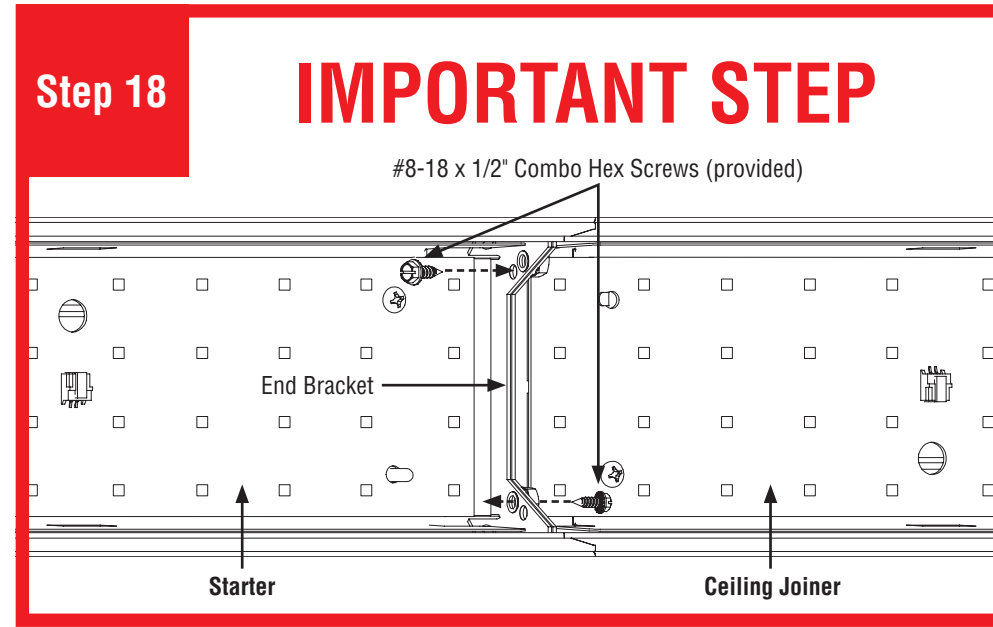

IMPORTANT STEP: Install 2 #8-18 x 1/2" combo hex screws (provided) into end bracket as shown. Screws can be installed from the left or right. **CAUTION: Do not over-tighten.**

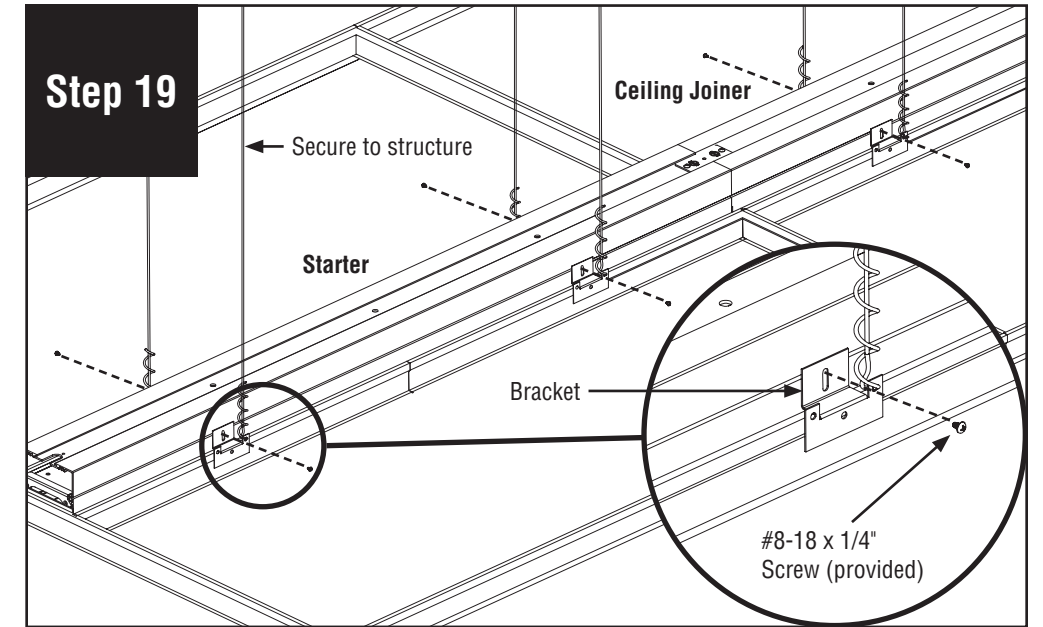

Connect all luminaires to building structure, as per code. Use #8-18 x 1/4" screws (provided) to install T-Bar brackets onto luminaires.

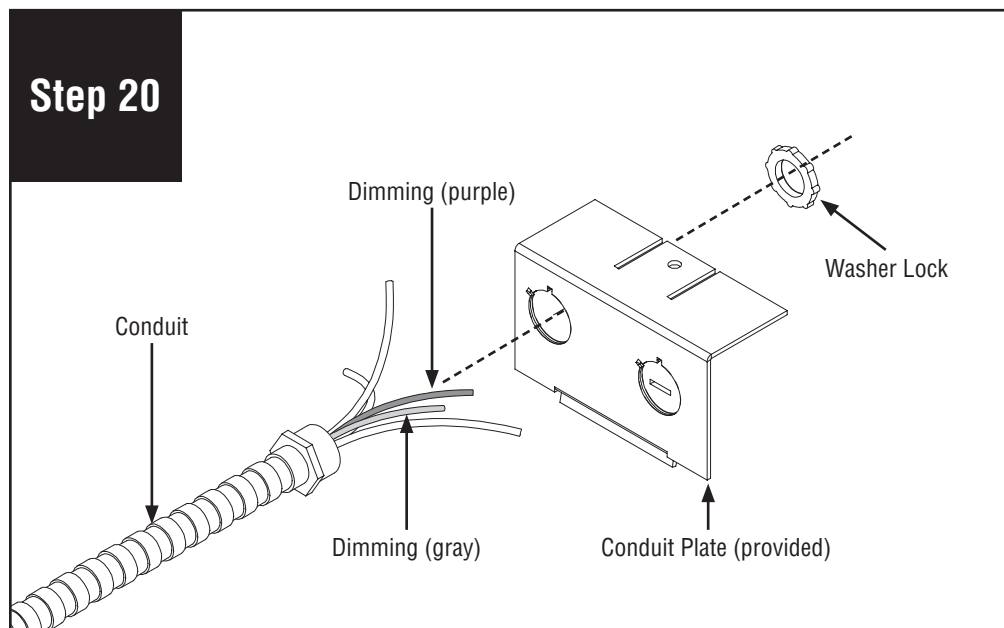

Remove conduit plate from end of the luminaire and insert conduit through conduit plate. **NOTE:** Purple and gray wires are for Low Voltage Control.

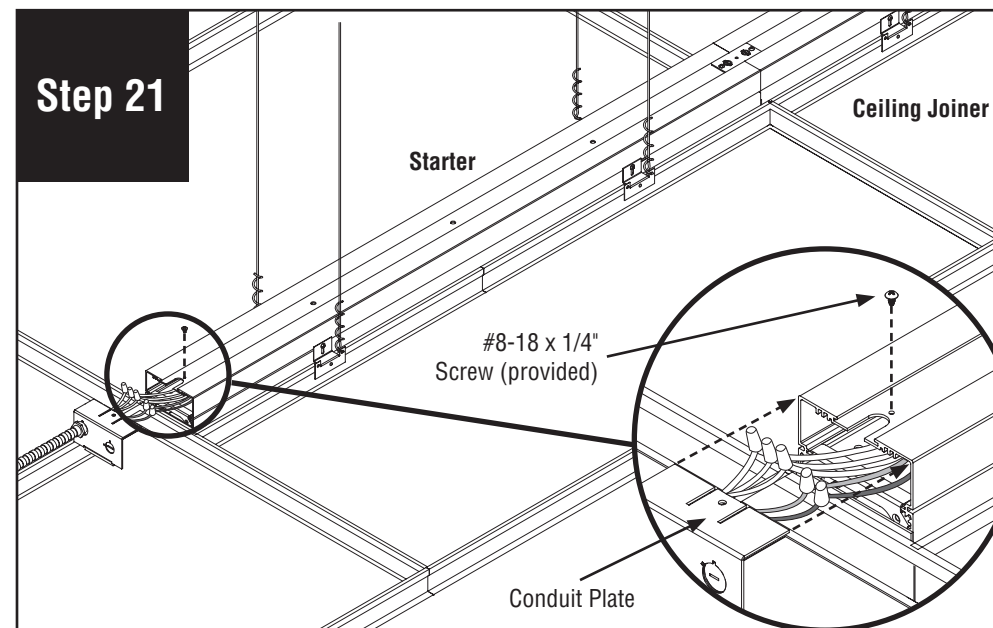

Make electrical connections and reinstall conduit plate to luminaire.

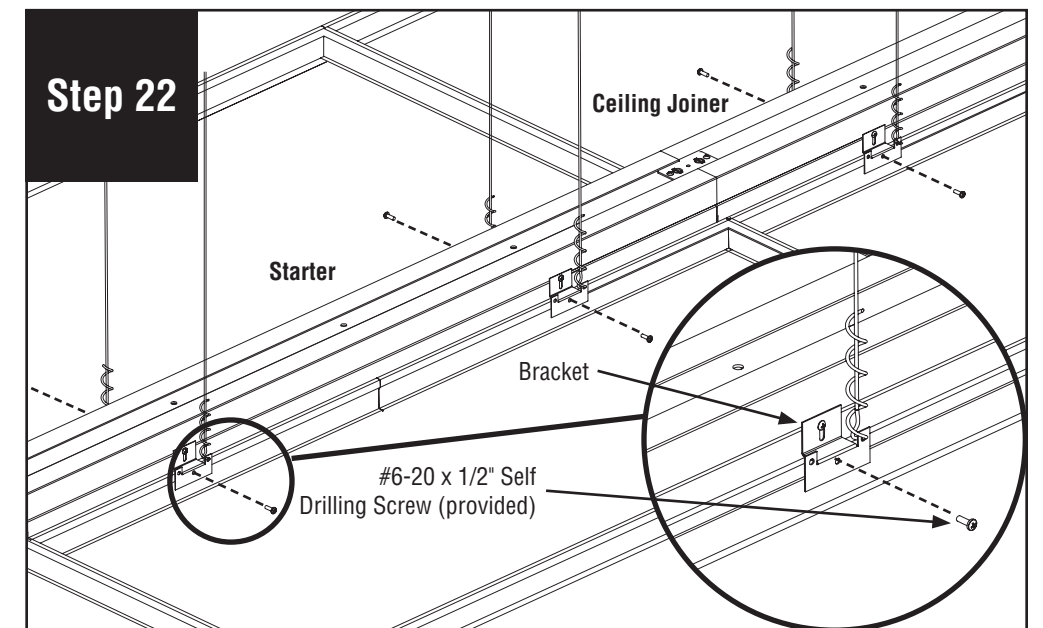

Secure all luminaires to T-Bar by driving #6-20 x 1/2" self drilling screws (provided) through T-Bar brackets into T-Bar.

Note: All power connections to be installed to local/national codes by a Certified Electrician.

HP-4 Recessed 1" T-Bar to Spackle Flange Installation Instructions

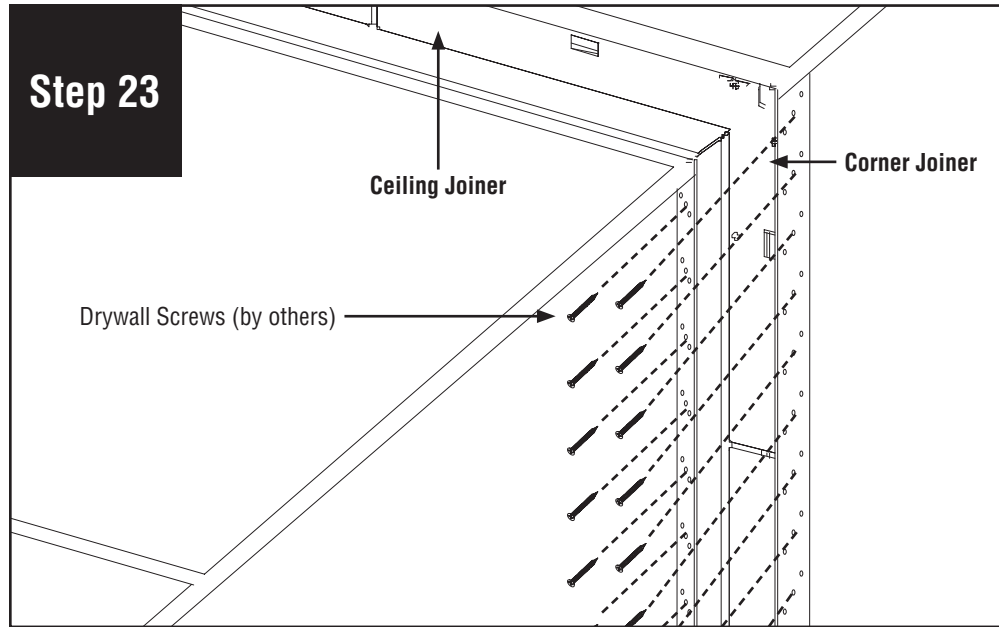

Fasten corner joiner to the wall with drywall screws (by others).

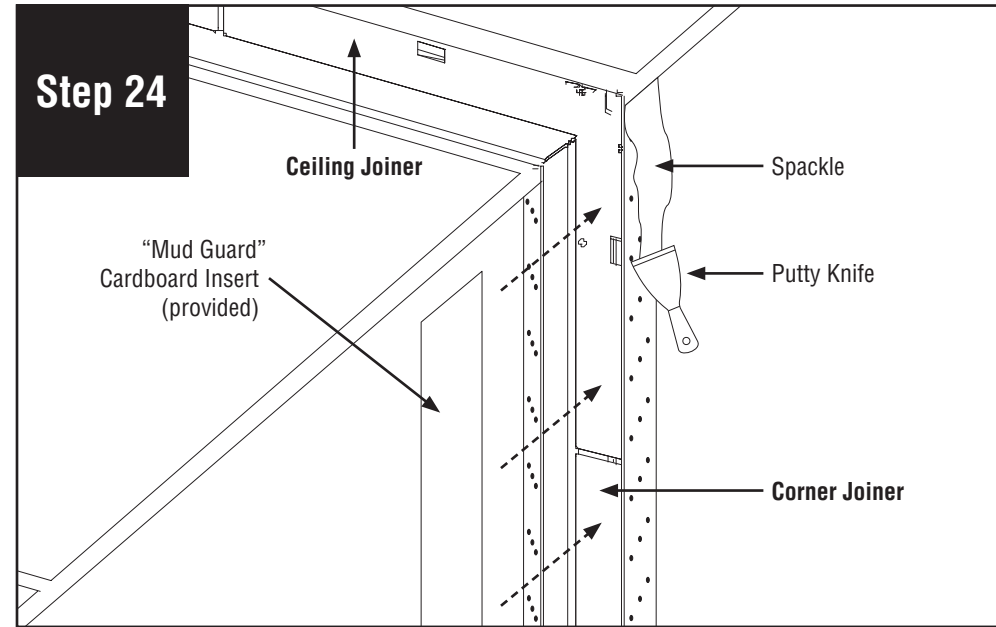

Install the "mud guards" cardboard inserts (provided) to help prevent spackle from getting into the luminaire. Use spackle to cover up the flange before reinstalling the diffuser.

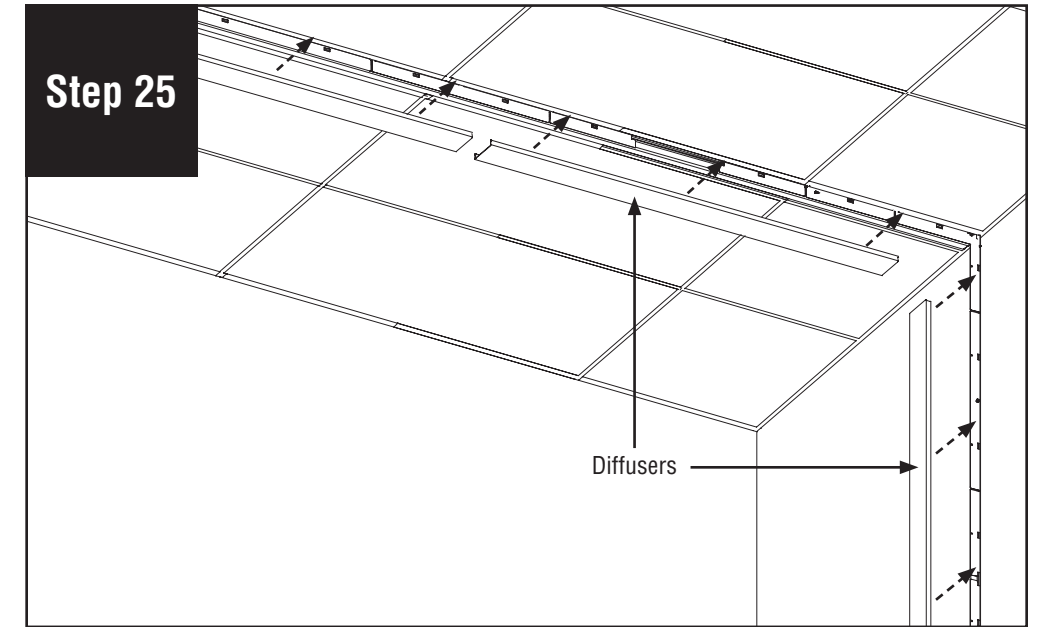

Once the spackling is complete, remove the mud guards, reinstall diffusers, and turn power on to luminaires. **NOTE:** If part of a longer run, diffuser will be reinstalled back into original luminaire section as lengths vary.

Note: All power connections to be installed to local/national codes by a Certified Electrician.