

## HP-6 Direct Mitered Corner Installation Instructions

Scan QR code for helpful video(s)

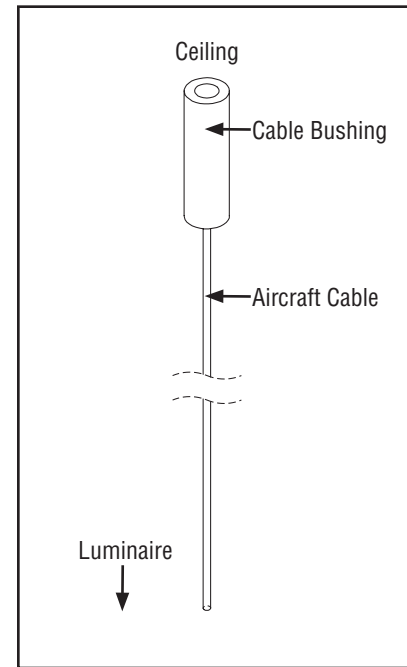

0 - 10V Dimming



Locate aircraft cables.

### Step 1

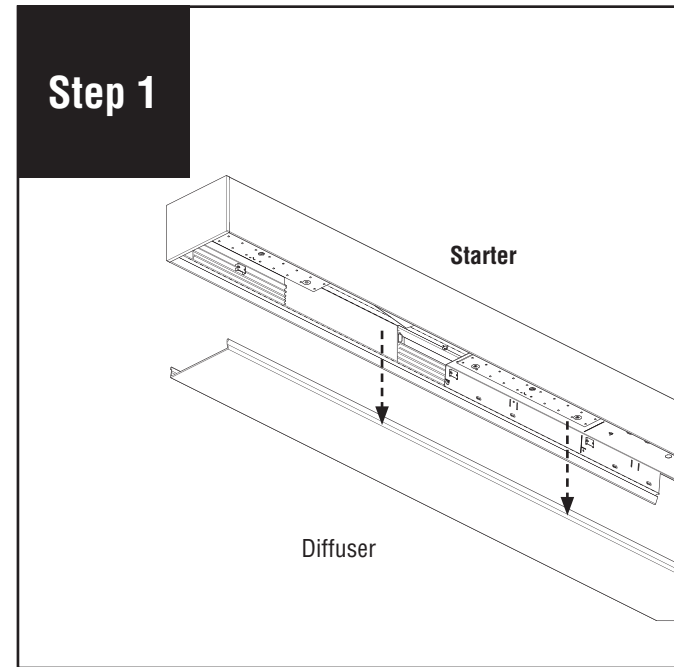

Remove diffusers and set aside to prevent it from getting dirty or damaged. **NOTE:** If part of a longer run, diffuser will be reinstalled back into original luminaire section as lengths vary.

### Step 2

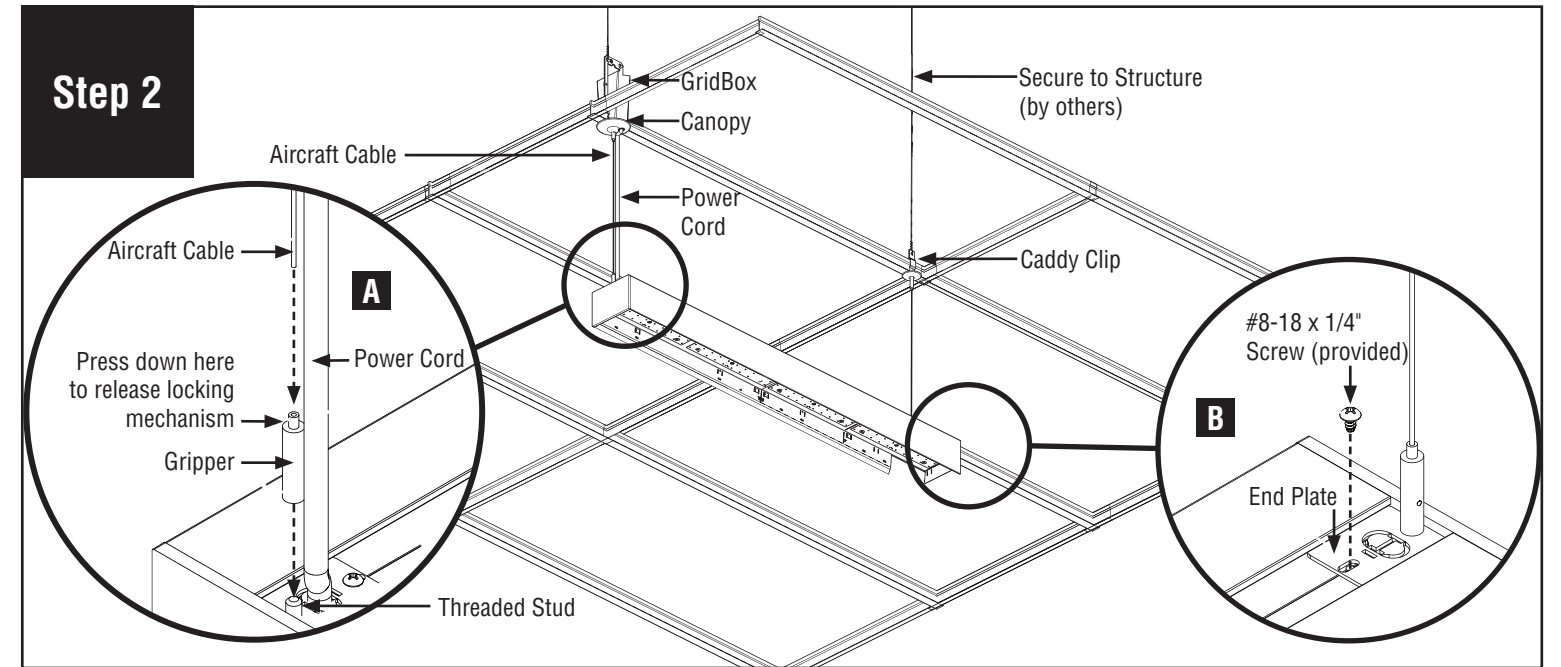

Install grippers onto threaded studs on both ends of the luminaire. Install GridBox™ and caddy clip onto ceiling grid, then canopies and aircraft cable assemblies. **A.** Align aircraft cables to grippers and insert on both ends of the luminaire. Adjust pendant to proper height and level. Press down on top of gripper to release locking mechanism if needed. Secure luminaire to structure using tie-wire (supplied by others) according to code. **B.** End plates are adjustable for custom mounting locations. Remove #8-18 x 1/4" screw from end plate, then slide end plate to desired location and reinstall #8-18 x 1/4" screw.

### Step 3

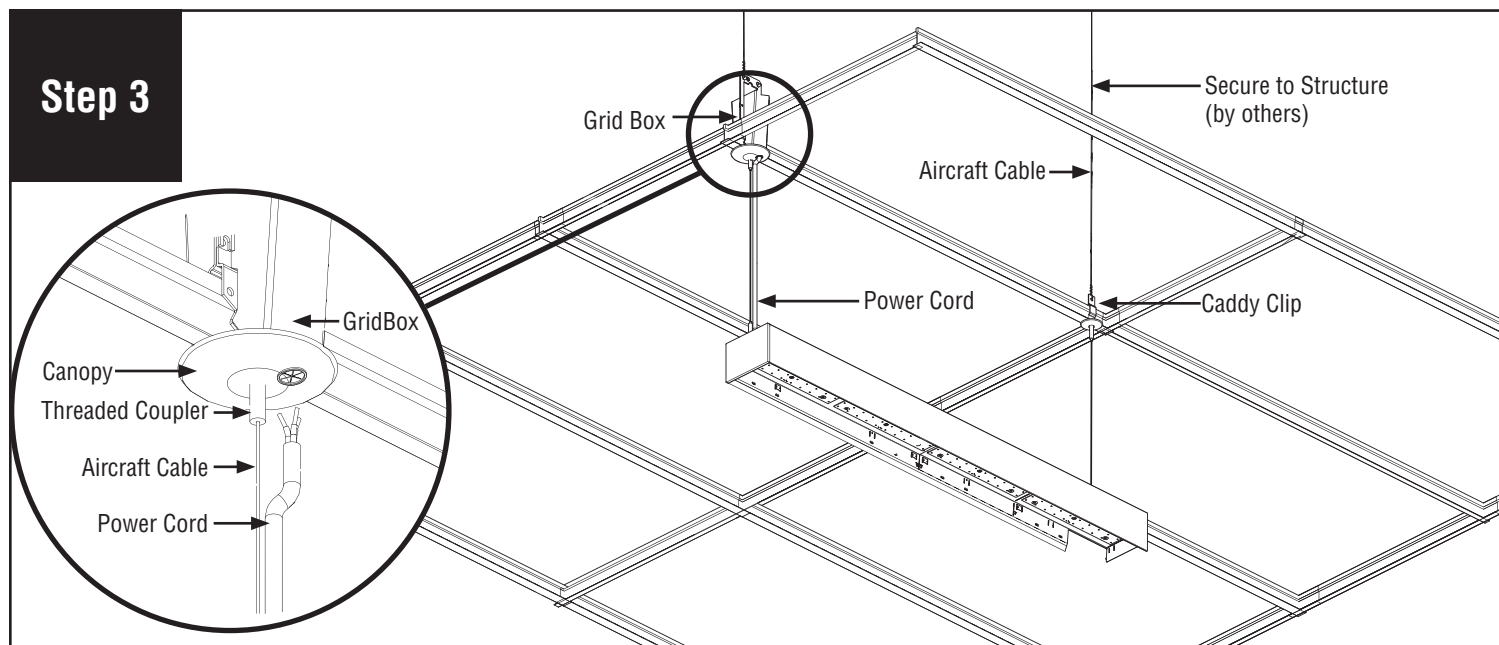

Install power cable through canopy and into GridBox™. Make electrical connections in GridBox.

### Step 4

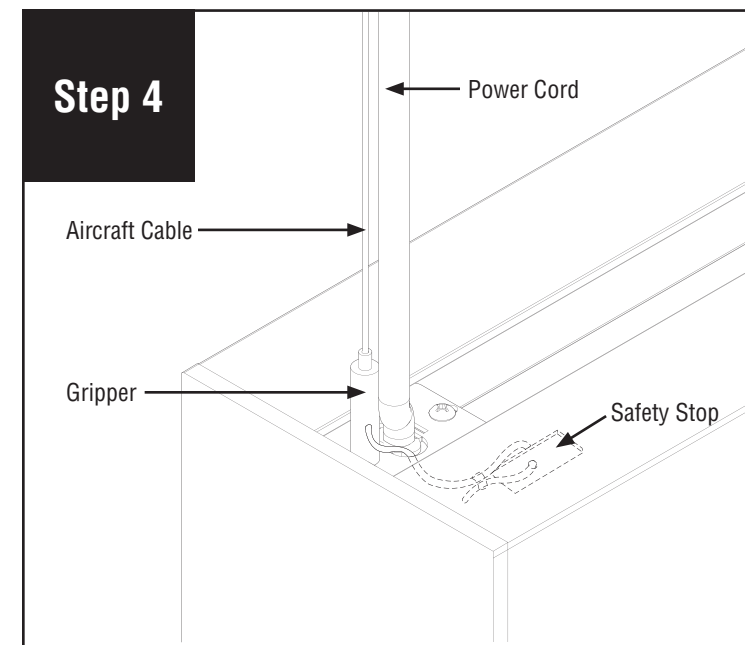

Slide safety stop and safety crimp up to the aircraft cable within 9" of cable gripper. Trim excess cable and insert safety bar assembly through feed hole.

### Step 5

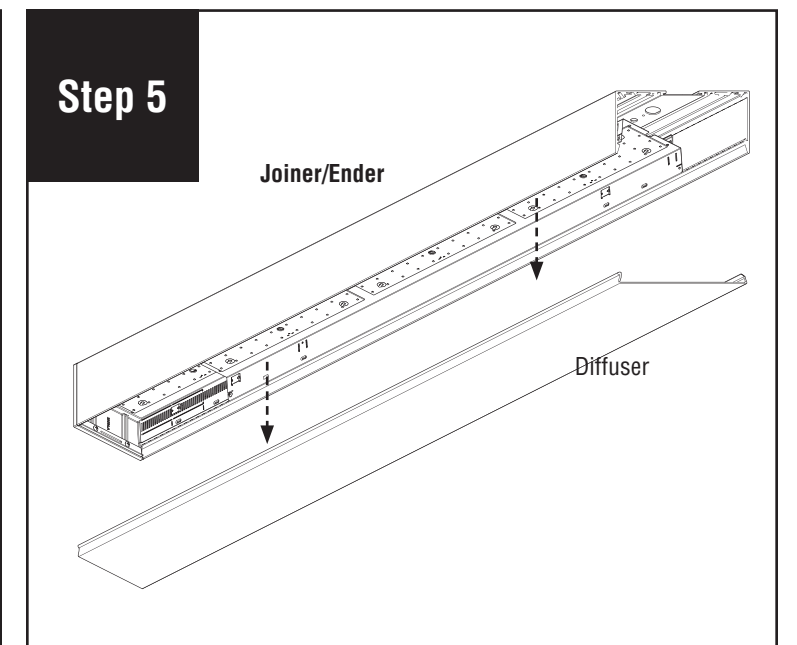

Remove diffuser from joiner/ender and set aside to prevent it from getting dirty or damaged. **NOTE:** If part of a longer run, diffuser will be reinstalled back into original luminaire section as lengths vary.

**Note:** All power connections to be installed to local/national codes by a Certified Electrician.

# HP-6 Direct Mitered Corner Installation Instructions

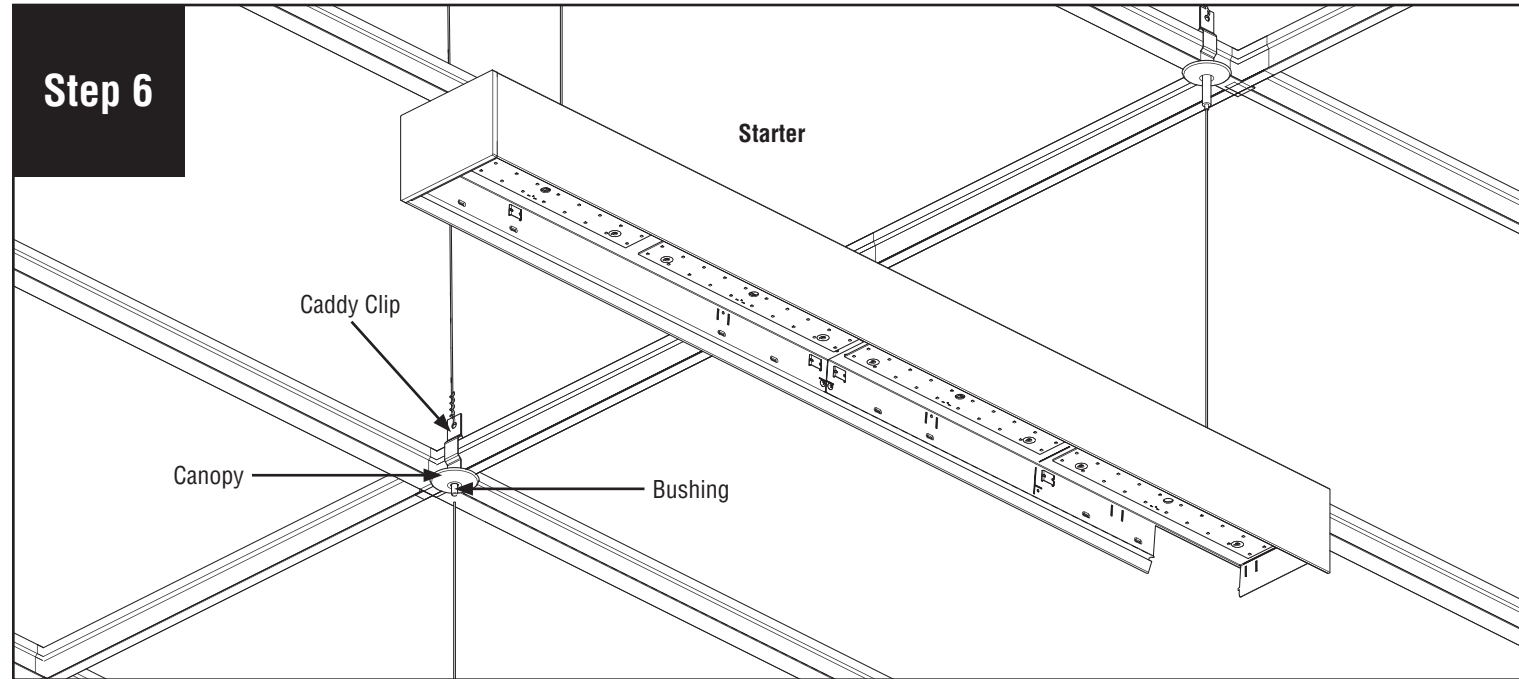

Install caddy clip for joiner/ender. Install canopy, cable bushing and aircraft cable onto caddy clip.

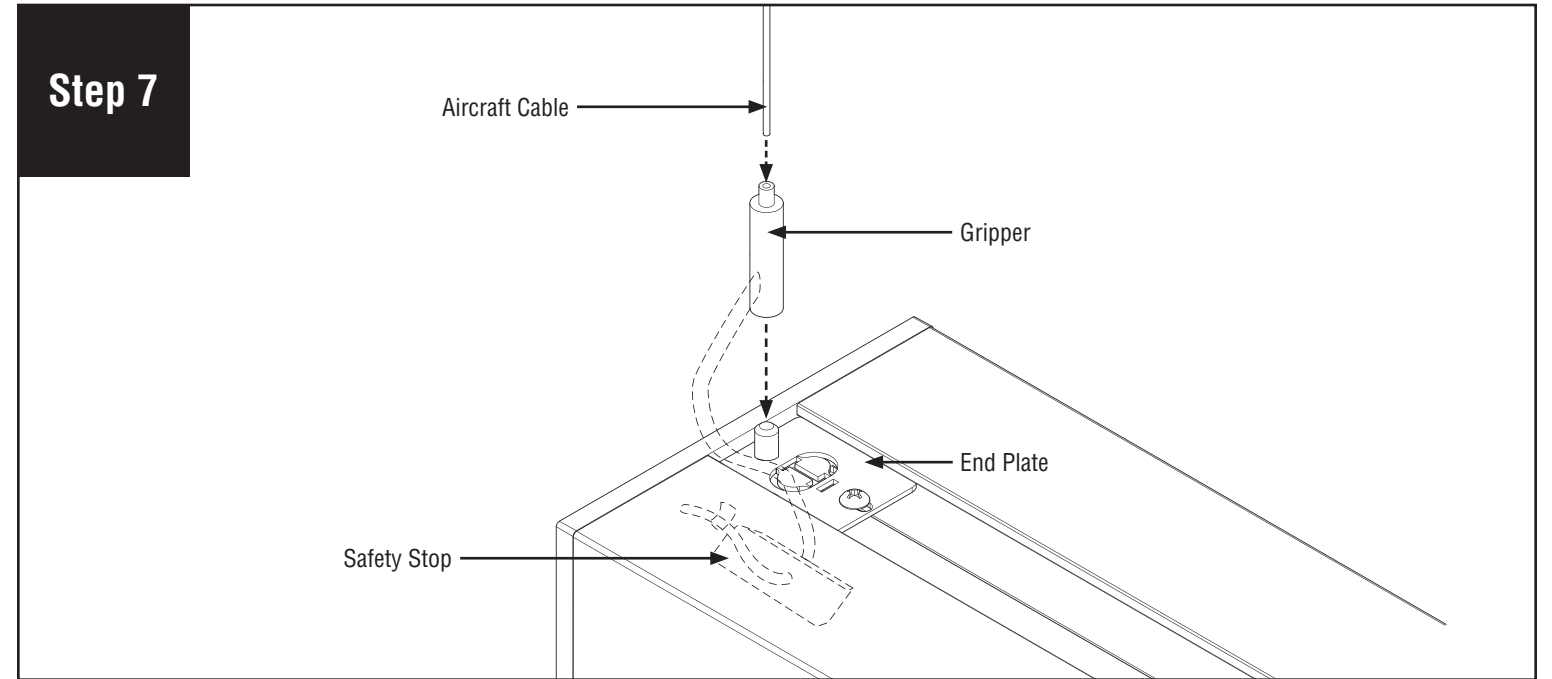

Install gripper onto end plate of luminaire then install aircraft cable into gripper. Adjust pendant to proper height and level. Slide safety stop and safety crimp up to the aircraft cable within 9" of cable gripper. Trim excess cable and insert safety bar assembly through feed hole.

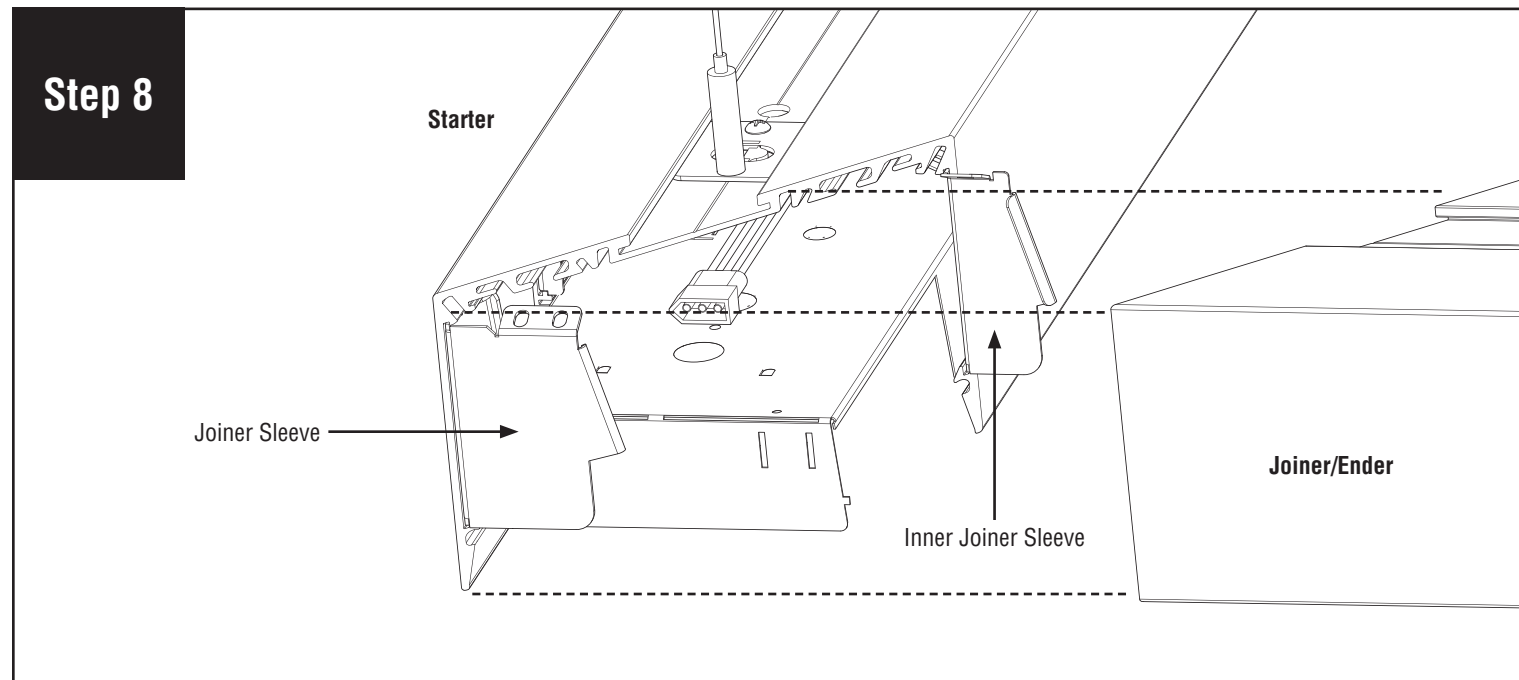

Align starter and joiner/ender luminaires and slide luminaires together.

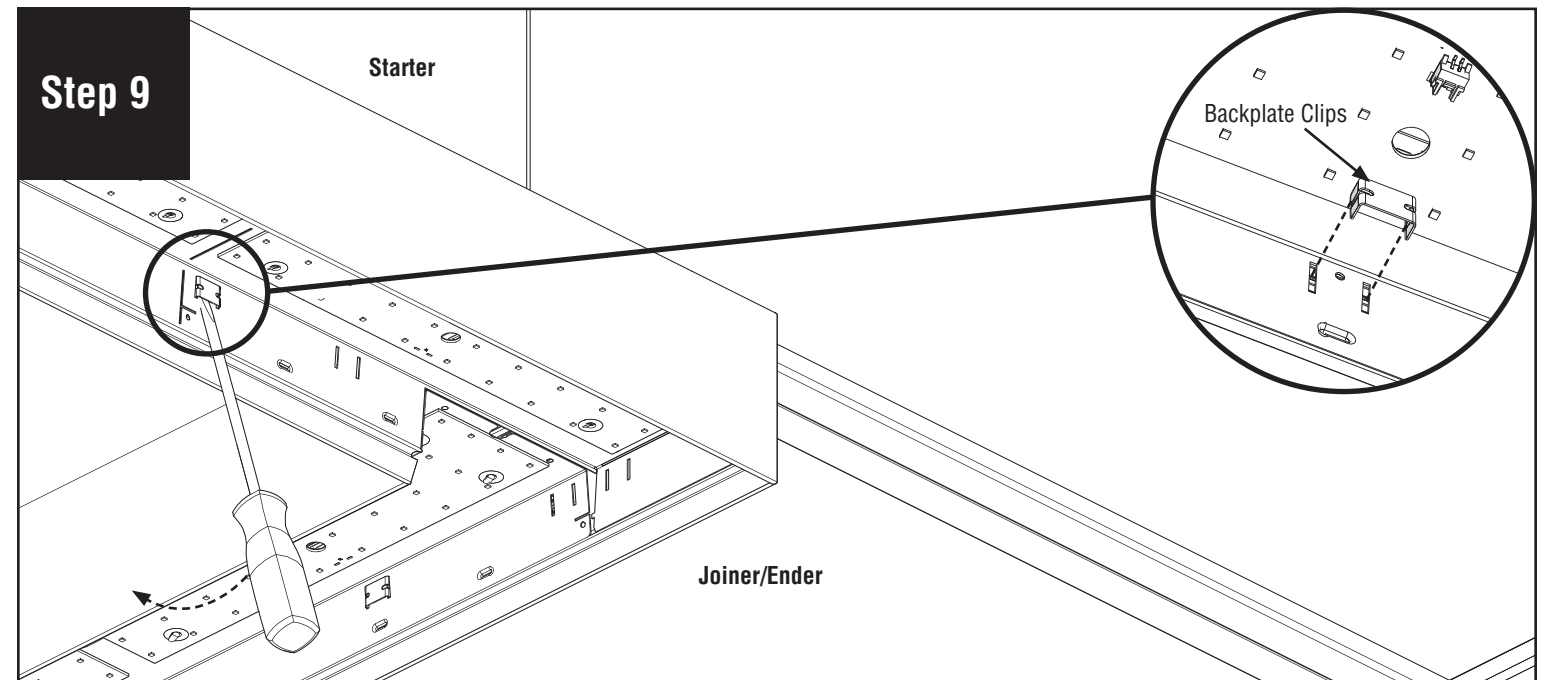

Remove backplate clips to release backplates. We recommend using a flat head screwdriver to get them loose. **CAUTION: Do not lose these pieces.**

**Note:** All power connections to be installed to local/national codes by a Certified Electrician.

# HP-6 Direct Mitered Corner Installation Instructions

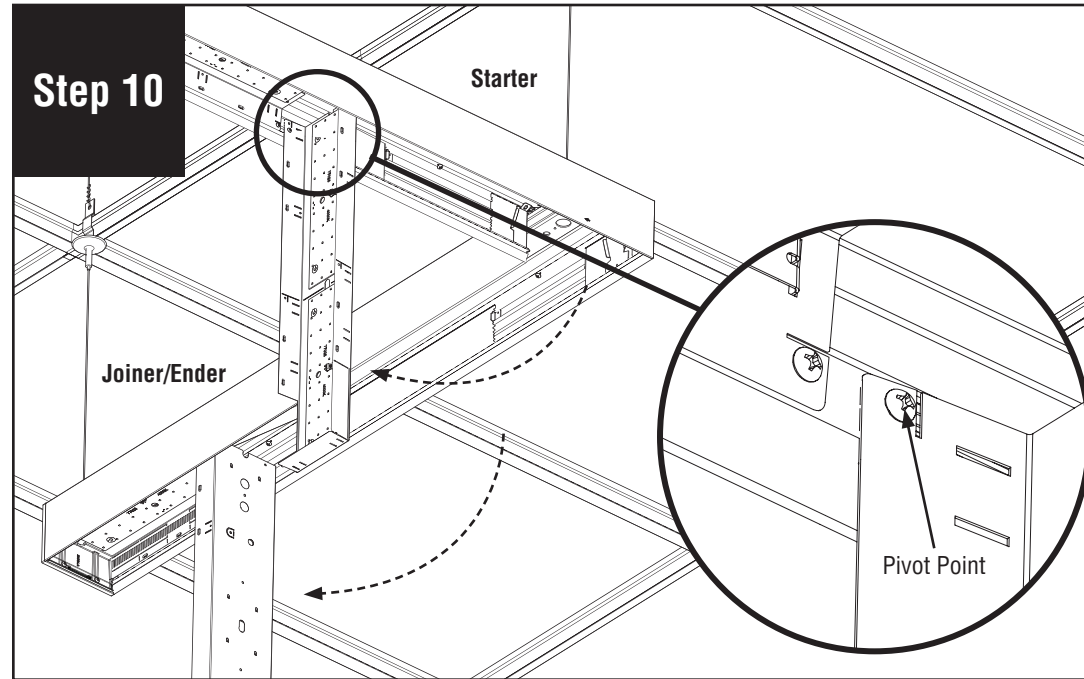

Slowly swing down backplate. **CAUTION: Do not twist the backplate when swinging down – it will come out of the support extrusion.** Note that the screws shown are the pivot point, and the backplate can be slid a few inches either way for ease of access to the driver space.

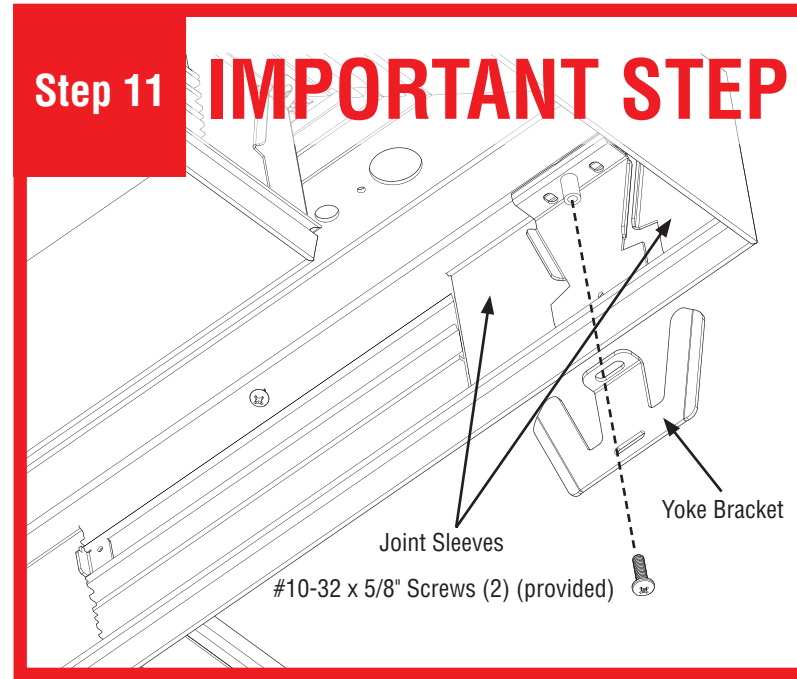

**IMPORTANT STEP:** Secure joint with two yoke brackets (provided) using 2 #10-32 5/8" screws (provided). When installed correctly these brackets will pull luminaires together to make a tight joint. **CAUTION: Do not over-tighten.**

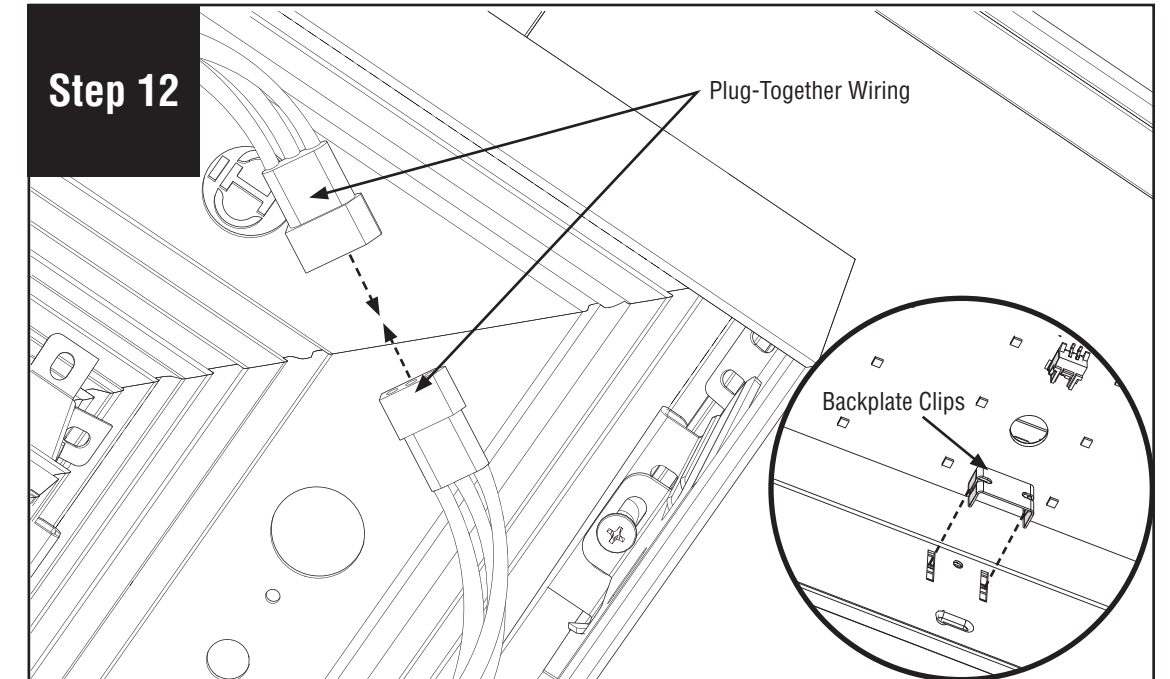

Connect plug-together wiring. Re-position the backplates and secure by reinstalling the backplate clips. Make sure wire connections are not pinched. (If 1 ft. backplate assembly is near joint, reconnect feed harness to LED board.)

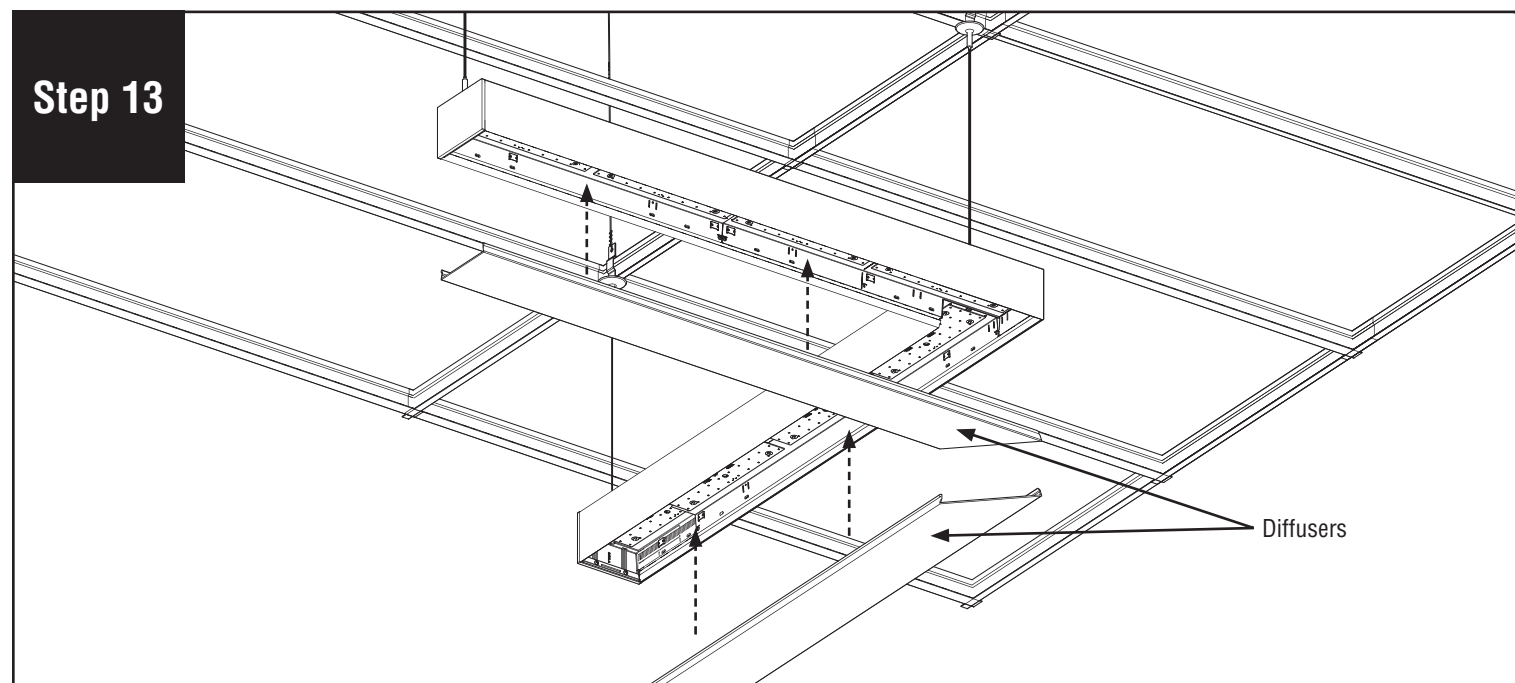

Reinstall diffusers and turn power on to luminaire. **NOTE:** If part of a longer run, diffuser will be reinstalled back into original luminaire section as lengths vary.

**Note:** All power connections to be installed to local/national codes by a Certified Electrician.