

HP-6 Recessed Flush Diffuser Tech Zone 6" T-Bar Starter/Independent Installation Instructions

FINELITE[®]
Better Lighting

Scan QR code for helpful video(s)



0 - 10V Dimming

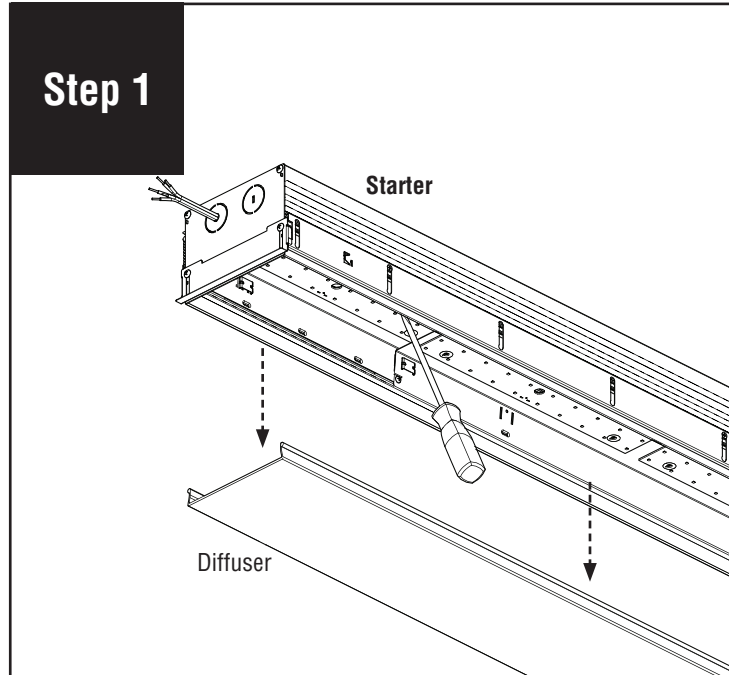

Remove diffuser and set aside to prevent it from getting dirty or damaged. **NOTE:** If part of a longer run, diffuser will be reinstalled back into original luminaire section as lengths vary.

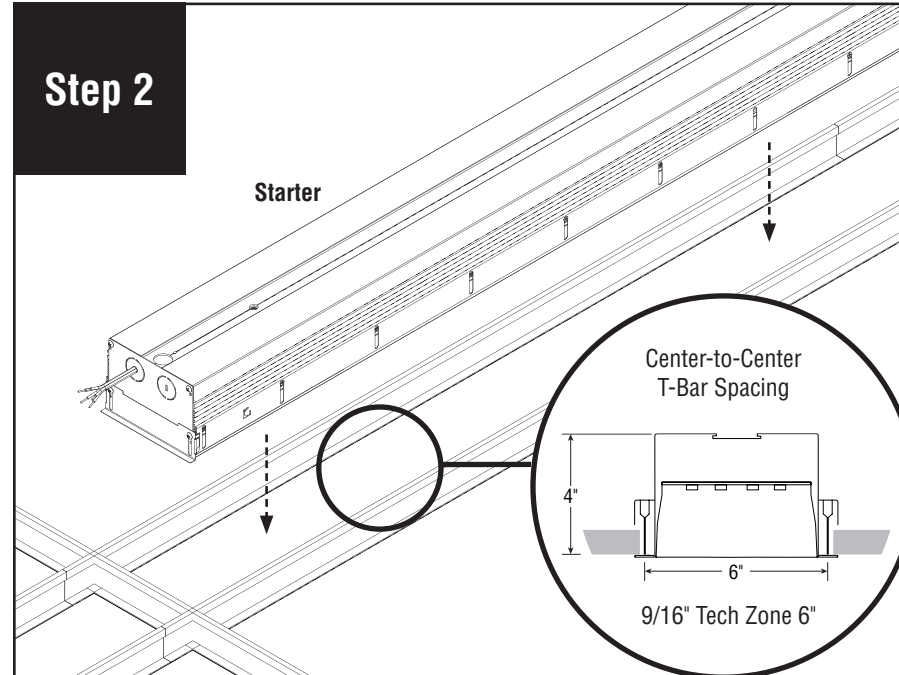

Configure T-Bar to luminaire size and leave an opening for luminaire as noted above. Make sure T-Bars are aligned at 90 degrees. Place luminaire on T-Bar.

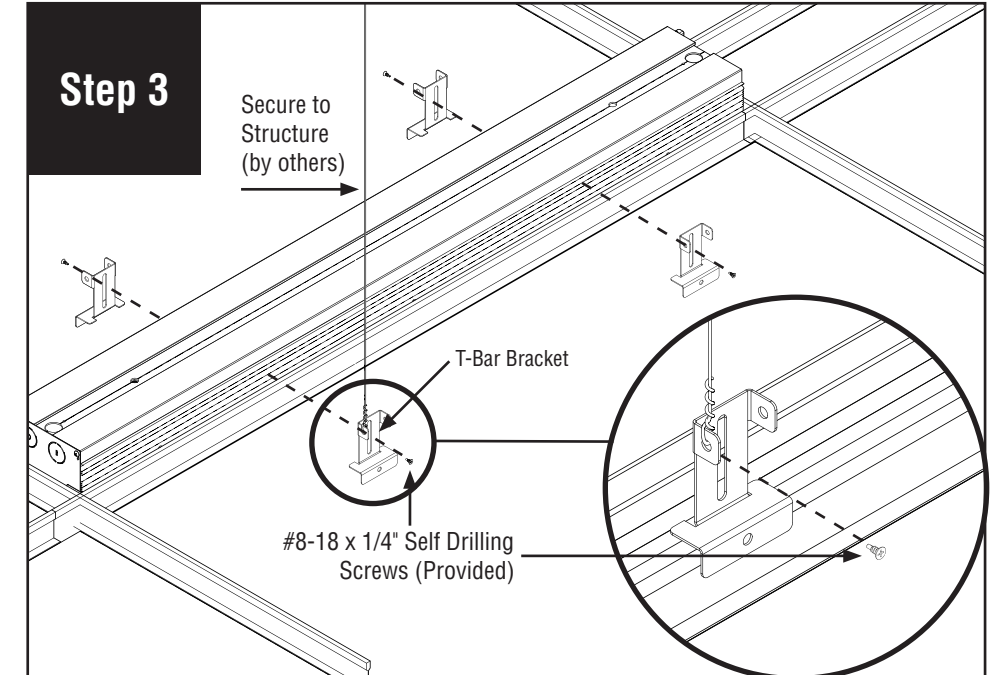

Install T-Bar bracket onto luminaire. Secure with #8-18 x 1/4" screws (provided). Secure luminaire to structure using tie-wire (by others), as per code.

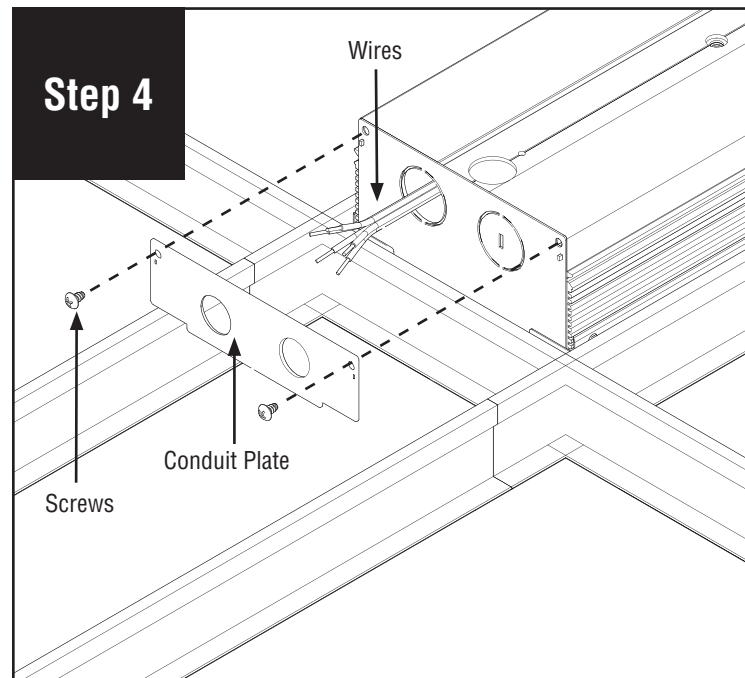

Remove conduit plate from luminaire. **NOTE:** Purple and gray wires are for Low Voltage Control.

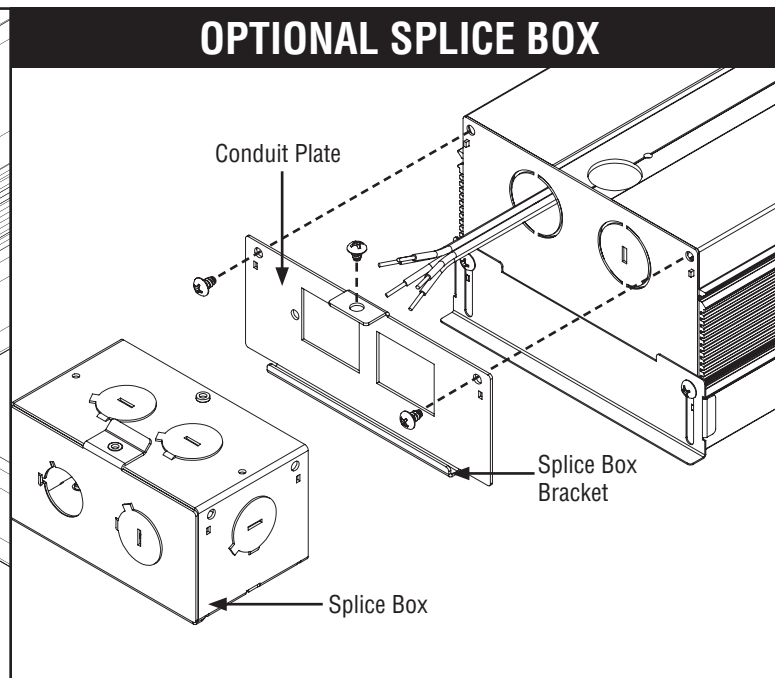

Attach optional splice box to conduit plate by hooking onto splice box bracket. Insert wires through feed hole.

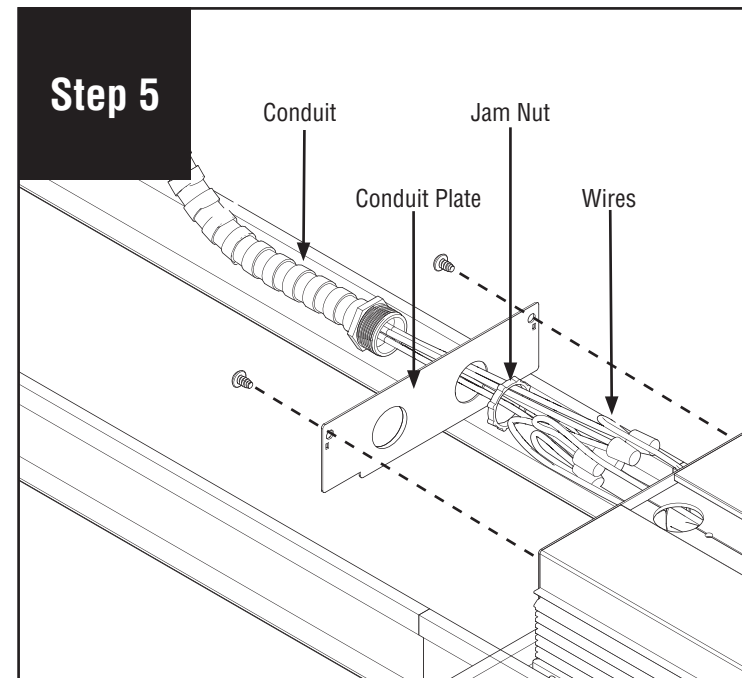

Run power cables through conduit plate and jam nut. Make electrical connections. Secure conduit onto conduit plate with jam nut, and reinstall conduit plate carefully not to damage any wiring.

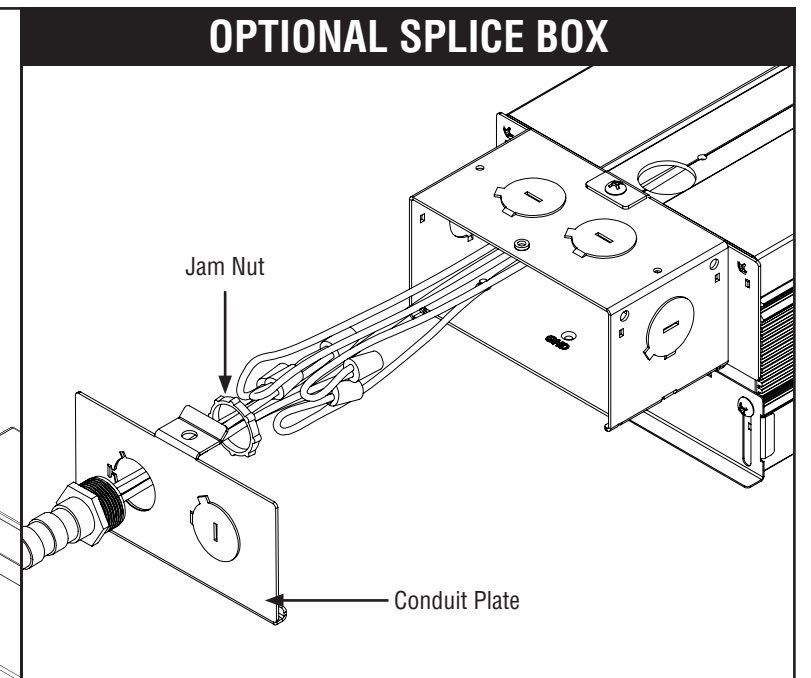

Run power cable through knock-out. Make electrical connection. Secure conduit on to splice box with jam nut and close conduit plate.

Note: All power connections to be installed to local/national codes by a Certified Electrician.

Finelite, Inc. • 30500 Whipple Road • Union City, CA 94587-1530 • (510) 441-1100 • Fax: (510) 441-1510 • www.finelite.com

HP-6 Recessed Flush Diffuser Tech Zone 6" T-Bar Starter/Independent Installation Instructions

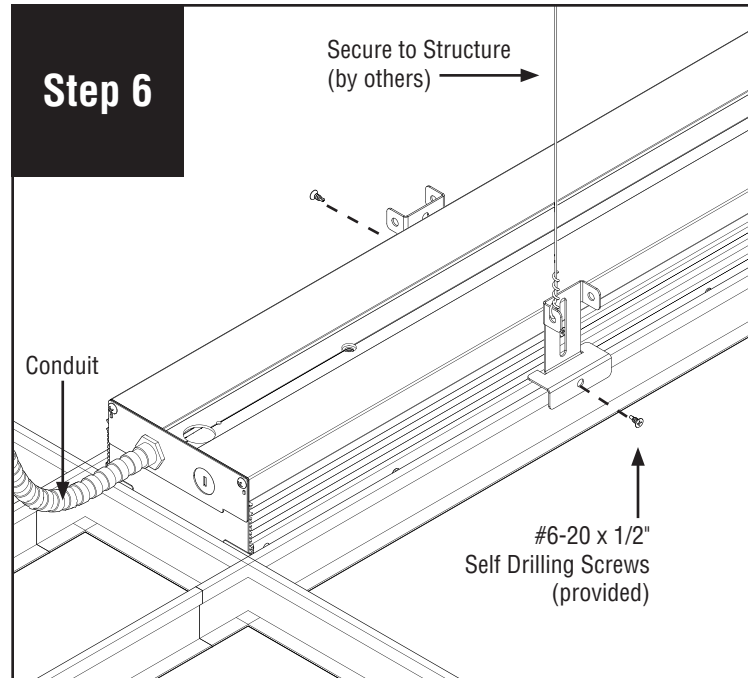

Secure luminaire to T-Bar with #6-20 x 1/2" self drilling sheet metal screws (provided).

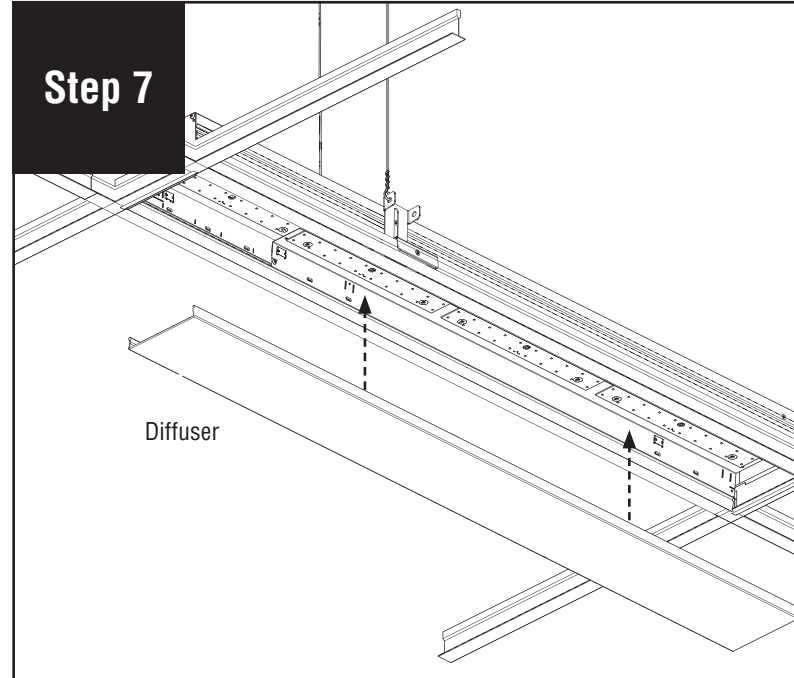

Reinstall diffuser and turn power on. **NOTE:** If part of a longer run, diffuser will be reinstalled back into original luminaire section as lengths vary.

Note: All power connections to be installed to local/national codes by a Certified Electrician.

HP-6 Recessed Flush Diffuser Tech Zone 6" T-Bar Joiner/Ender Installation Instructions

Scan QR code for helpful video(s)



0 - 10V Dimming

Step 1

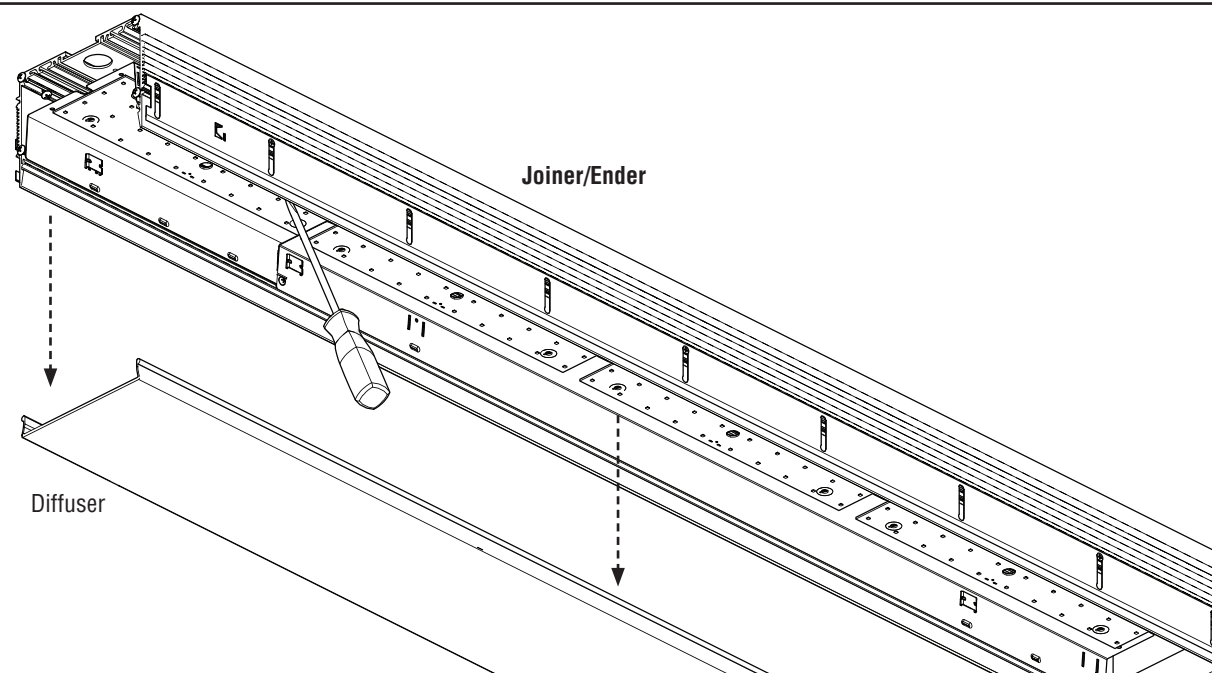

Remove diffuser from joiner/ender and set aside to prevent it from getting dirty or damaged. **NOTE:** If part of a longer run, diffuser will be reinstalled back into original luminaire section as lengths vary.

Step 2

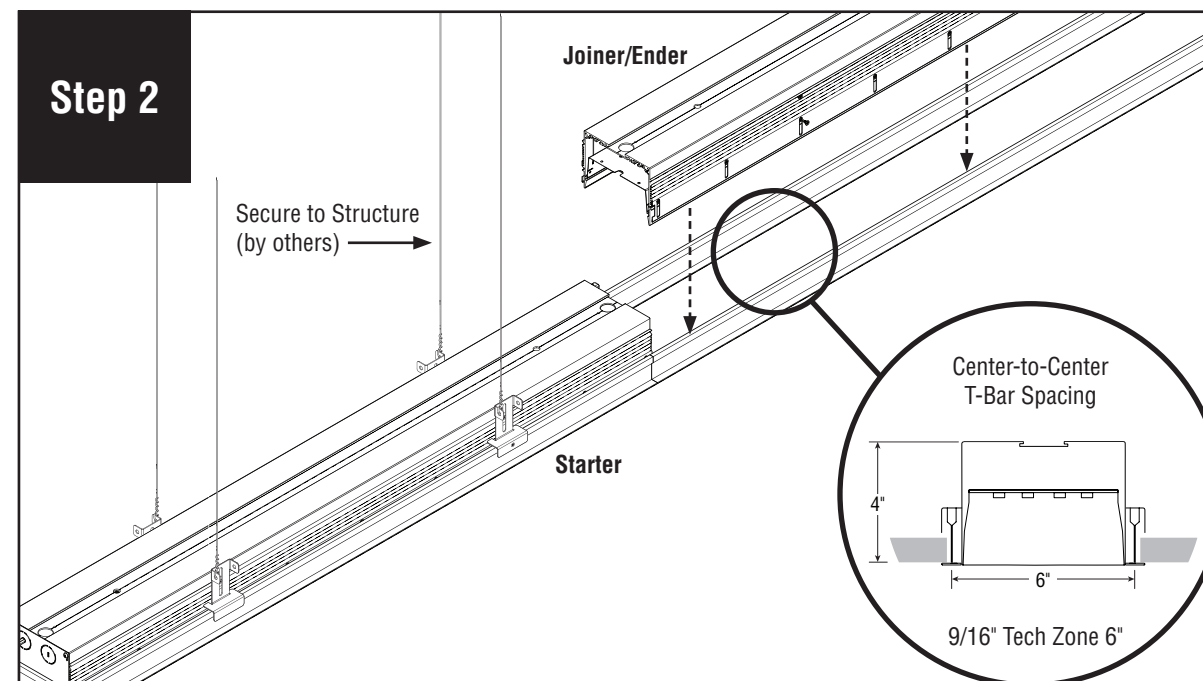

Install joiner/ender onto ceiling next to starter.

Step 3

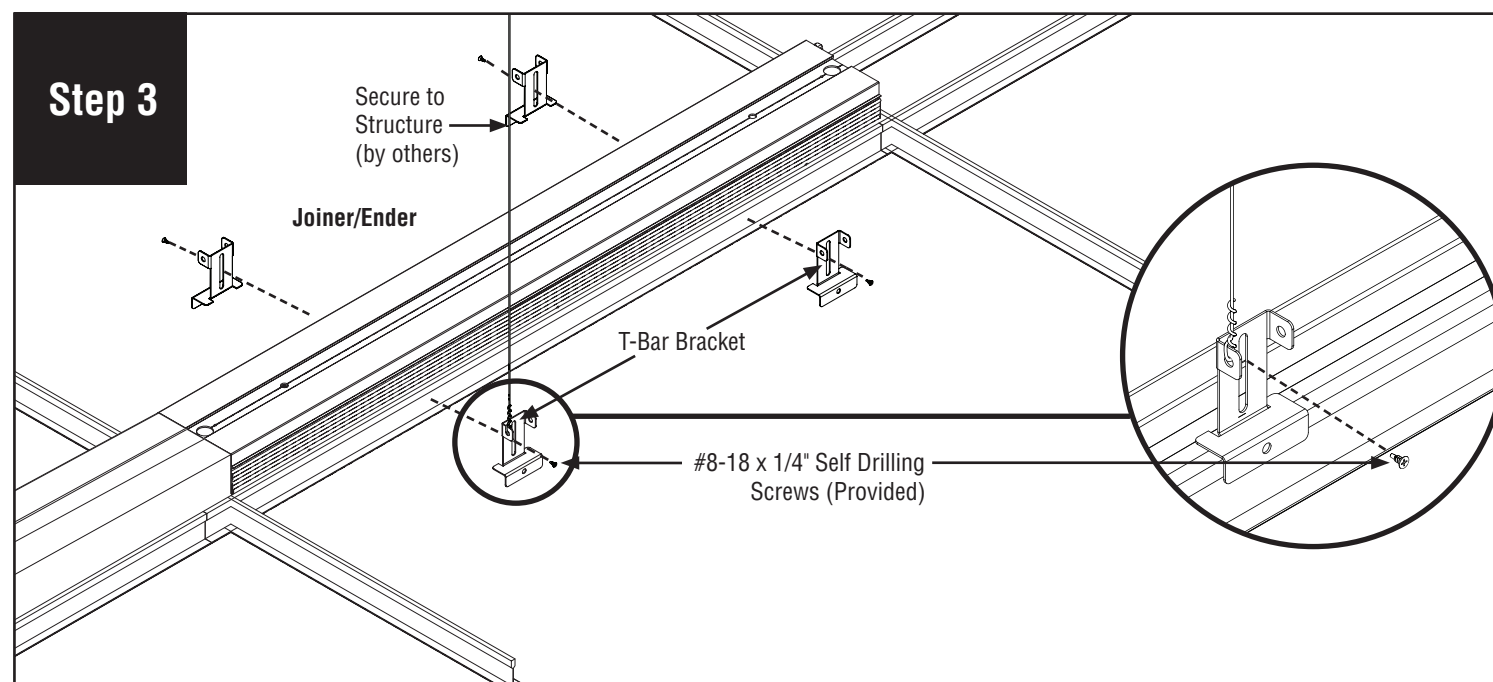

Install T-Bar brackets onto joiner/ender luminaire. Secure with #8-18 x 1/4" screws (provided). Secure luminaire to structure using tie-wire (by others), as per code.

Step 4

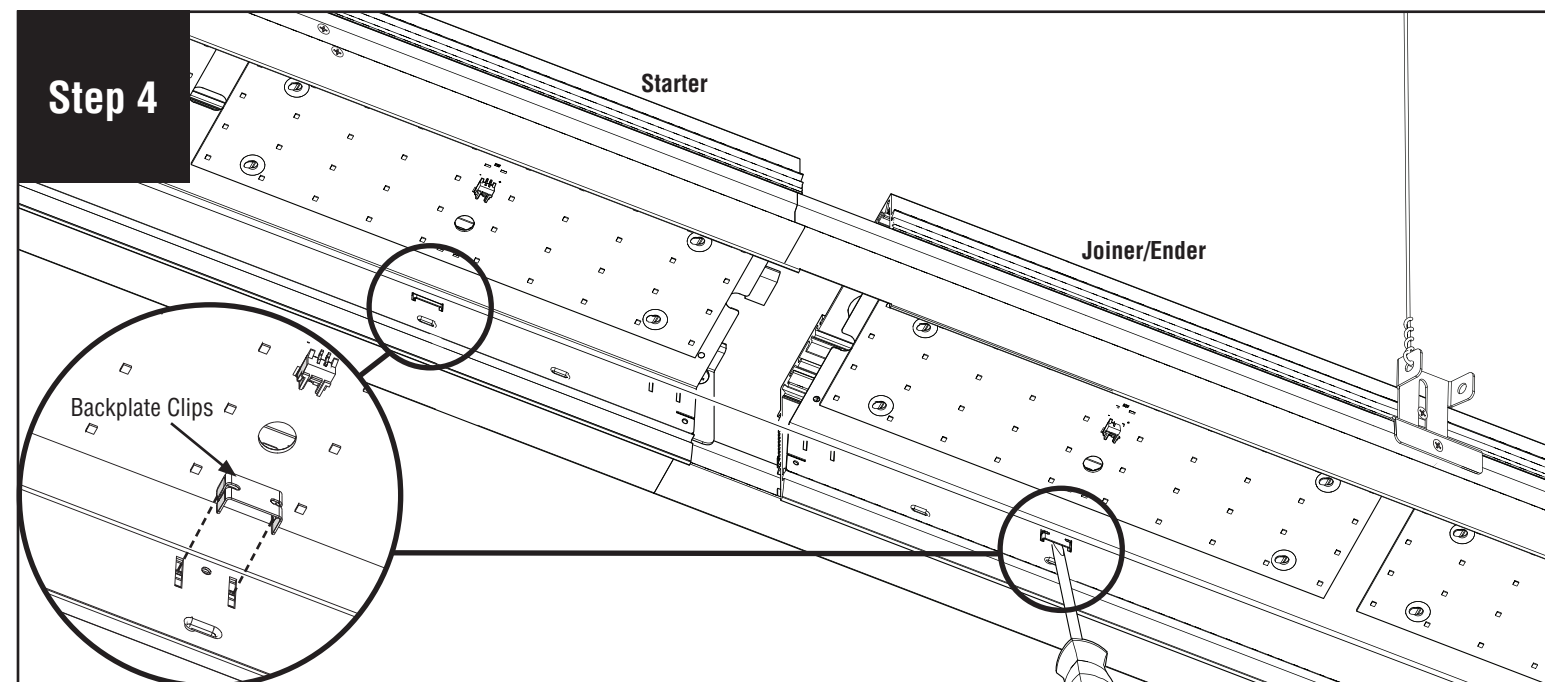

Remove backplate clips to release the backplates. We recommend using a flat head screwdriver to remove them. **CAUTION: Do not lose these pieces.**

Note: All power connections to be installed to local/national codes by a Certified Electrician.

HP-6 Recessed Flush Diffuser Tech Zone 6" T-Bar Joiner/Ender Installation Instructions

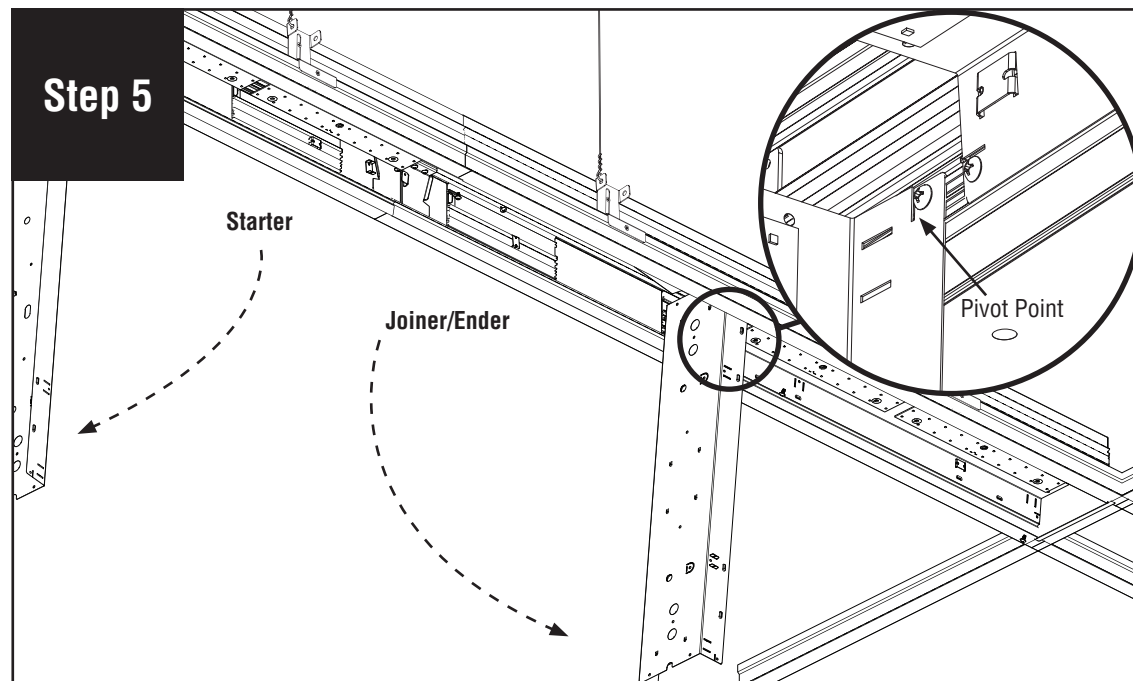

Slowly swing down backplate. **CAUTION: Do not twist the backplate when swinging down – it will come out of the support extrusion.** Note that the screws shown are the pivot points, and the backplate can be slid a few inches either way for ease of access to the driver space.

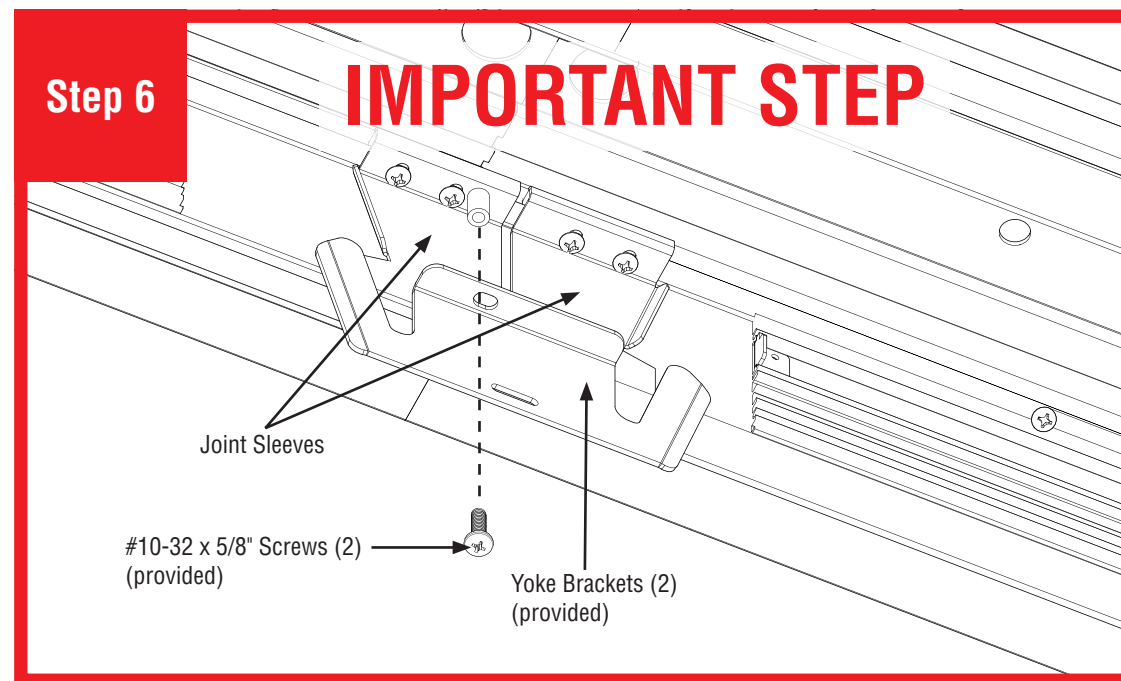

IMPORTANT STEP: Secure joint with two yoke brackets (provided) using two #10-32 x 5/8" screws (provided). When installed correctly these brackets will pull luminaires together to make a tight joint. **CAUTION: Do not over-tighten.**

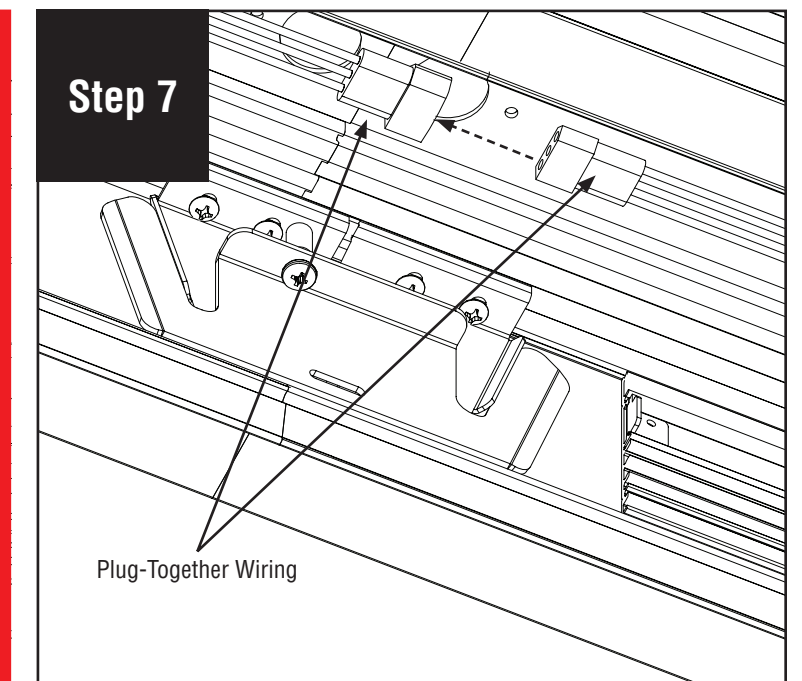

Connect plug-together wiring connections.

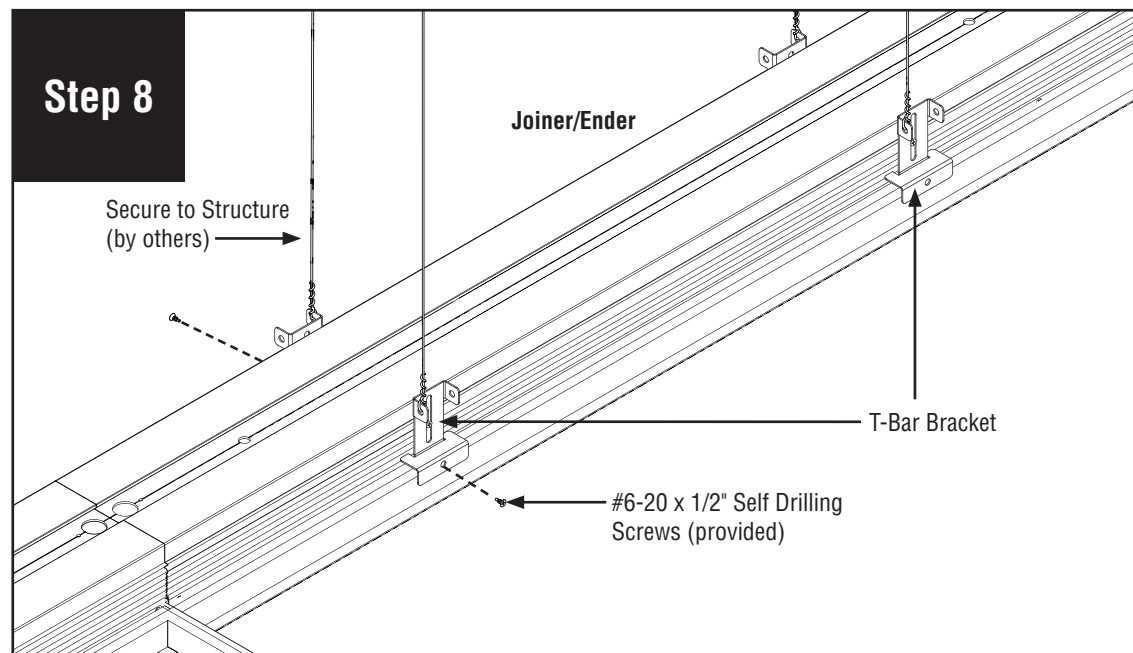

Secure luminaire to T-Bar with #6-20 x 1/2" self drilling sheet metal screws (provided).

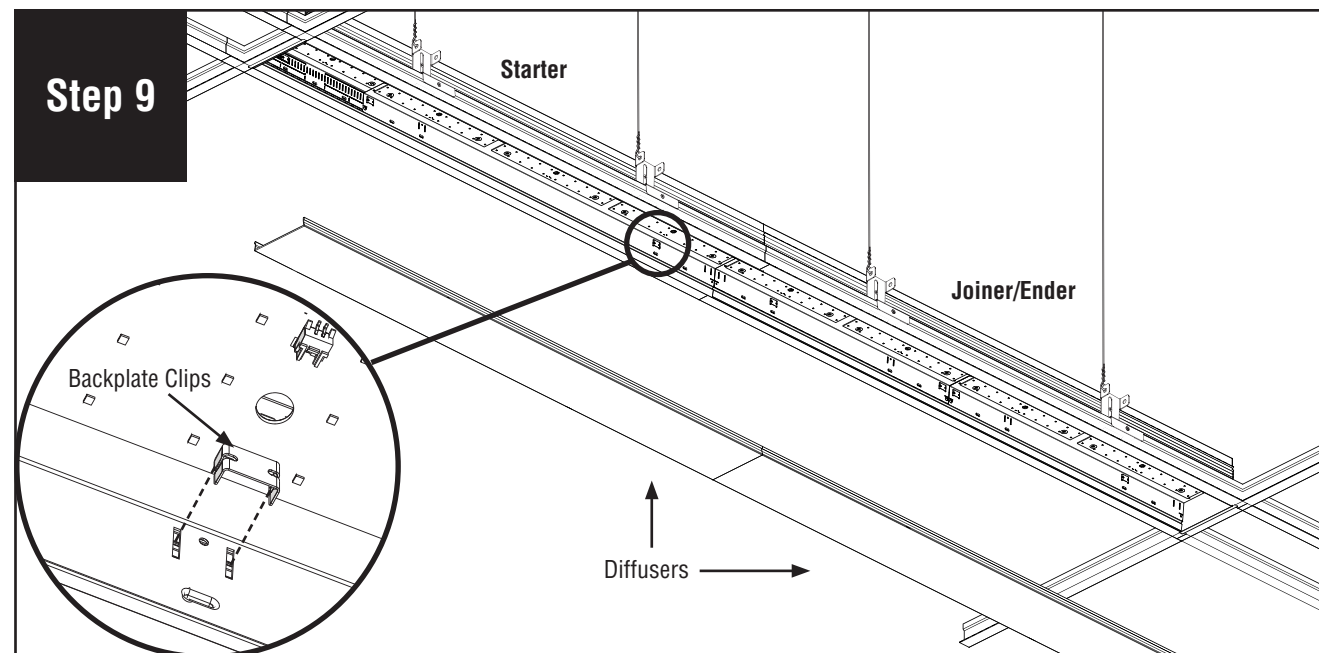

Replace backplates by holding them in their original position and pushing the clips back in. Make sure wire connections are not pinched. (If a 1ft. backplate assembly is near joint, reconnect feed harness to LED board.) Replace diffuser and turn power on to luminaire. **NOTE:** If part of a longer run, diffuser will be reinstalled back into original luminaire section as lengths vary.

Note: All power connections to be installed to local/national codes by a Certified Electrician.